



COMPAc® I **COMPAc® II**
Air Conditioner Product Manual
Vertical Wall-Mount Air Conditioners
with Front Control Box Panel

Installation & Operation Manual

9-11 EER Vertical Wall-Mount Air Conditioners

MODELS:

AVPA 12-20-24-30-36-42-48-60-72

HVEA 24-30-36-42-49-60

AVHA 12-20-24-30-36-42-48-60

HVESA 36-42-49-60

AVHSA72



IMPORTANT

This manual may include information for options and features which may not be included on the unit being installed. Refer to the unit data label or Model Identification to determine which features and options this unit is equipped with.

INSTALLER: Affix the instructions on the inside of the building adjacent to the thermostat.
END USER: Retain this manual for future reference.

Manufactured By:

A Division of the AIRXCEL® Commercial Group

P.O. Box 400 • Cordele, Georgia 31010 • 156 Seedling Drive • Cordele, Georgia 31015
(229) 273-3636 • Fax (229) 273-5154

E-mail: marvairsales@airxcel.com • Internet: www.Marvair.com

The most current version of this manual can be found at www.Marvair.com.

How To Use This Manual

This manual is intended to be a guide to Marvair ComPac family of vertical air conditioners. It contains installation, troubleshooting, maintenance, warranty, and application information. The information contained in this manual is to be used by the installer as a guide only. This manual does not supersede or circumvent any applicable national or local codes.

If you are installing the ComPac unit, first read Chapter 1 and scan the entire manual before beginning the installation as described in Chapter 2. Chapter 1 contains general, descriptive information and provides an overview which can speed up the installation process and simplify troubleshooting.

If a malfunction occurs, follow this troubleshooting sequence:

1. Make sure you understand how the ComPac unit works (Chapters 1 & 3).
2. Identify and correct installation errors (Chapter 2).
3. Refer to the troubleshooting information in Chapter 4.

If you are still unable to correct the problem, contact the Factory at 1-800-841-7854 for additional assistance.

Please read the following “Important Safety Precautions” before beginning any work.

Important Safety Precautions

1. USE CARE when LIFTING or TRANSPORTING equipment.
2. TRANSPORT the UNIT UPRIGHT. Laying it down on its side may cause oil to leave the compressor and breakage or damage to other components.
3. TURN ELECTRICAL POWER OFF AT THE breaker or fuse box BEFORE installing or working on the equipment. LINE VOLTAGES ARE HAZARDOUS or LETHAL.
4. OBSERVE and COMPLY with ALL applicable PLUMBING, ELECTRICAL, and BUILDING CODES and ordinances.
5. SERVICE may be performed ONLY by QUALIFIED and EXPERIENCED PERSONS.
 - * Wear safety goggles when servicing the refrigeration circuit
 - * Beware of hot surfaces on refrigerant circuit components
 - * Beware of sharp edges on sheet metal components
 - * Use care when recovering or adding refrigerant
6. Use COMMON SENSE - BE SAFETY-CONSCIOUS

This is the safety alert symbol . When you see this symbol on the ComPac unit and in the instruction manuals be alert to the potential for personal injury. Understand the signal word DANGER, WARNING, CAUTION and IMPORTANT. These words are used to identify levels of the seriousness of the hazard.

 **DANGER** Failure to comply will result in death or severe personal injury and/or property damage.

 **WARNING** Failure to comply could result in death or severe personal injury and/or property damage.

 **CAUTION** Failure to comply could result in minor personal injury and/or property damage.

 **IMPORTANT** Used to point out helpful suggestions that will result in improved installation, reliability or operation.

AS PART OF THE MARVAIR CONTINUOUS IMPROVEMENT PROGRAM, SPECIFICATIONS ARE SUBJECT TO CHANGE WITHOUT NOTICE.

© 08/2018 Marvair, Division of Airxcel, Inc.

 **WARNING**

- If the information in these instructions are not followed exactly, a fire may result causing property damage, personal injury or loss of life.
- Read all instructions carefully prior to beginning the installation. Do not begin installation if you do not understand any of the instructions.
- Improper installation, adjustment, alteration, service or maintenance can cause property damage, personal injury or loss of life.
- Installation and service must be performed by a qualified installer or service agency in accordance with these instructions and in compliance with all codes and requirements of authorities having jurisdiction.

INSTALLER: Affix the instructions on the inside of the building adjacent to the thermostat.

END USER: Retain these instructions for future reference.

Table of Contents

Chapter 1 ComPac Description & Specifications

1.1	General Description	5
1.2	Model Identification	5
1.3	Serial Number Date Code	5
1.4	Air Flow, Weights and Filter Sizes.....	6
1.5	General Operation	7
1.6	Electronic Control Board Mode of Operation.....	7
1.7	Optional Controls and Packages	9
1.8	Electrical Operation	11
1.9	Economizer Components	19

Chapter 2 Installation

2.1	Equipment Inspection.....	23
2.2	Installation Requirements.....	23
2.3	Installation Materials	25
2.4	Porting and Duct Work	26
2.5	Fresh Air Hood Installation	29
2.6	Bracket Installation	29
2.7	Mounting the Unit	29
2.8	Vertical Economizer and Gravity Dampers (HVESA 36 & 60 Models Only).....	31
2.9	Electrical Connections	32

Chapter 3 Start-Up

3.1	Check-Out of Cooling Cycle	36
3.2	Check-Out of Heating Cycle.....	36

Chapter 4 Troubleshooting

4.1	Overview	37
4.2	Failure Symptoms Guide.....	37
4.3	Compressor Troubleshooting	38
4.4	Control Board Diagnosis.....	39

Table of Contents

Chapter 5 Maintenance

5.1 Scheduled Maintenance	40
---------------------------------	----

Chapter 6 Warranty

6.1 Airxcel Commercial Group Limited Product Warranty	41
---	----

Parts List and Exploded Views	42
-------------------------------------	----

Appendix A

Installation Instructions for Field Installed Electric Heaters	43
--	----

Illustrations

Figure 1a. Typical Electrical Schematic - Model AVPA & AVHA	12
Figure 1b. Typical Electrical Schematic - Model AVPA & AVHA	13
Figure 1c. Typical Electrical Schematic - Model HVEA	14
Figure 1d. Typical Electrical Schematic - Model HVEA	15
Figure 1e. Typical Electrical Schematic - Model HVESA (Alternate Construction)	16
Figure 1f. Typical Electrical Schematic - Model HVESA (Alternate Construction)	17
Figure 1g. Typical Electrical Schematic - Model AVHSA (Alternate Construction)	18
Figure 2. Dry Bulb sensor	20
Figure 3. Enthalpy Sensor Temperature Control Points	21
Figure 4. Electrical Controls, HVESA Alternate Construction	21
Figure 5. Economizer Control Board	22
Figure 6. Back Panel Configuration for AVPA/AVHA12 Air Conditioners	27
Figure 7a. Fresh Air Hood Damper, Models 24-72	29
Figure 7b. Fresh Air Hood Damper, Models AVPA/AVHA12	29
Figure 8a. Wall Mounting Detail	30
Figure 8b. Wall Mounting Detail	30
Figure 9a. Humidistat Wiring Details	34
Figure 9b. Thermostat Connection Diagram	34
Figure 9c. CommStat™ Touch HVAC Controller Wiring Detail	35
Figure 9d. CommStat™ 3 HVAC Controller Wiring Detail	35

Tables

Table 1 CFM @ External Static Pressure	6
Table 2 Return Air Filter Sizes	6
Table 3 Shipping Weights	6
Table 4 Minimum Clearances	24
Table 5 Voltage Limitations	25
Table 6 Maximum Static Pressure	28

Chapter 1 Description & Specifications

1.1 General Description

The Marvair ComPac® is a series of vertical wall-mounted air conditioning systems that provide heating, cooling, and ventilation for electronic equipment shelters, process control centers, and other applications with high internal heat gains. The series includes multiple sizes and nominal cooling capacities from 11,000 to 72,000 BTUH. Resistance heating elements are available in various wattages.

The AVPA models are available with nominal cooling capacities of 12,000 to 72,000 BTUH's and Energy Efficiency Ratios (EER's) of 9.0 to 10.0. The AVHA models are available with nominal cooling capacities of 12,000 to 60,000 BTUH's and EER's of 10.0. HVEA modes are available with cooling capacities of 24,000 to 60,000 BTUH and EER's of 10.50 to 11.75. HVESA models are identical to the HVEA models, but have a 2-stage compressor. The ComPac Product Data Sheets have detailed information on the capacities and efficiencies for each model.

See Appendix A for instructions on field installation of electric heat.

ComPac air conditioners feature an exclusive electronic control board. The control board consolidates several of the electrical components and improves the air conditioner's reliability. The control board replaces the blower relay, the lockout relay, the compressor time delay and the timed low pressure bypass. In addition, the control board has LED's to indicate operating status and fault conditions to assist the service technician. A complete description of functions of the control board is in Section 1.6.

ComPac models are designed for easy installation and service. Major components are accessible for service beneath external panels.

All units have internal disconnects (optional on 380V and 575V). Follow local codes for external disconnect requirements.

ComPac units have a 0-15% manual outside air damper as standard equipment. Marvair ComPac models are available with an optional factory installed economizer for 100% free cooling with outside air.

1.2 Model Identification

The model identification number is found on the data sticker. Rating plate located on side panel.

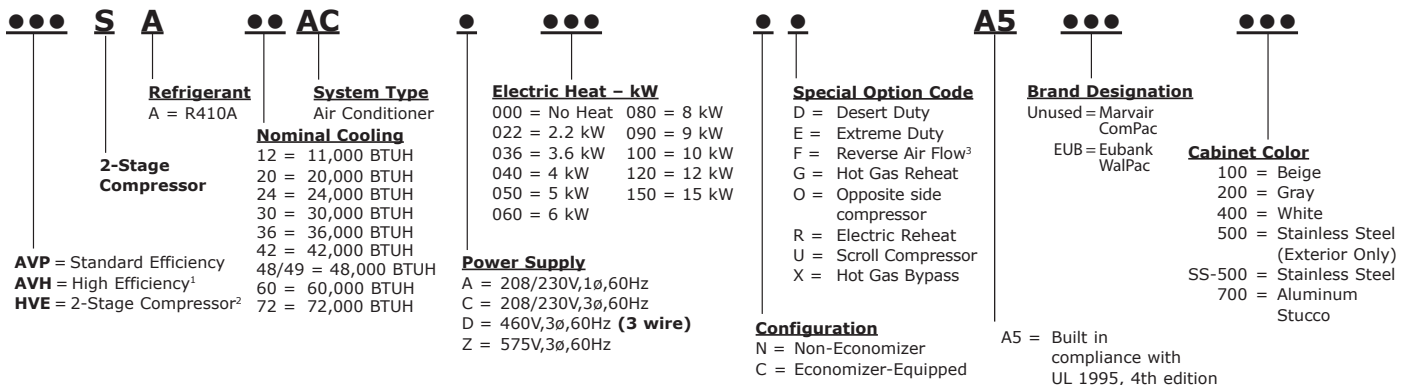

¹AVH models utilize a 1-Stage compressor, except the AVHSA72, which has a 2-Stage compressor as standard.

²All HVES models feature a 2-Stage compressor.

³The standard configuration is with the supply (conditioned) air at the top of the unit and the return air below it. In the reverse air flow configuration, the return is at the top and the supply air below it.

1.3 Serial Number Date Code

A = January	E = May	J = September	D = 2014	H = 2018
B = February	F = June	K = October	E = 2015	I = 2019
C = March	G = July	L = November	F = 2016	J = 2020
D = April	H = August	M = December	G = 2017	K = 2021

1.4 Air Flow, Weights and Filter Sizes

Complete electrical and performance specifications and dimensional drawings are in the Marvair ComPac Product Data Sheets.

MODEL	0.10	0.15	0.20	0.25	0.30	0.40	0.50
AVPA/AVHA12	450	420	390	360			
AVPA24/AVHA20/24	860	825	810	740	670		
AVPA/AVHA30	1100	1050	1000	960	920	810	
AVPA/AVHA36	1310	1265	1220	1185	1150	1060	
AVPA/AVHA42			1650	1585	1520	1450	1360
AVPA/AVHA48			1900	1830	1760	1700	1620
AVPA/AVHA60			1900	1830	1760	1700	1620
AVPA72			2100	1950	1800	1730	1660
HVEA24	800	785	770	725	680	600	500
HVEA30	1200	1150	1100	1050	1000	900	800
HVEA36	1290	1230	1170	1115	1060	1000	920
HVEA42	1500	1430	1360	1295	1230	1160	1070
HVEA49	1900	1850	1800	1700	1600	1500	1350
HVEA60	1900	1850	1800	1700	1600	1500	1350
HVESA36	1290	1230	1170	1115	1060	1000	920
HVESA42	1500	1430	1360	1295	1230	1160	1070
HVESA49	1900	1850	1800	1700	1600	1500	1350
HVESA60	1900	1850	1800	1700	1600	1500	1350
AVHSA72	1900	1850	1800	1700	1600	1500	1350

Values in bold are the minimum air flow.

Air flow ratings of 208-230 volt units are at 230v. Air flow ratings of 460 volt units are at 460 volts. Operation of units at a voltage different from the rating point will affect air flow.

Table 1. CFM @ External Static Pressure (Wet Coil) (IWG)

MODEL	INCHES	MILLIMETERS	PART NUMBER	FILTERS PER UNIT	MERV RATING
AVPA/AVHA12 (Non-Economizer)	20 x 10 x 2	508 x 254 x 52	91974	1	8
AVPA12 (With Economizer)	22¼ x 6¼ x 2	565 x 159 x 51	80172	1	8
AVHA12 (With Economizer)	12 x 25 x 1	305 x 635 x 25	93181	1	8
AVPA20/24 & AVHA20/24	25 x 16 x 2	635 x 406 x 52	80137	1	8
AVPA/AVHA30/36 & HVEA24	30 x 16 x 2	762 x 406 x 52	80138	1	8
AVPA/AVHA42/48/60 & HVEA30/36/42 & HVESA30/36/42	36½ x 22 x 2	927 x 559 x 52	80162	1	8
AVPA/AVHA72 & HVEA49/60 & HVESA49/60	18 x 24 x 2	457 x 610 x 52	81257	2	8
AVHSA72	18 x 30 x 2	457 x 762 x 52	93184	2	8

Table 2. Return Air Filter Sizes

MODEL	LBS	KG
ComPac Non-Economizer		
AVPA/AVHA12	175	79.5
AVPA24/AVHA20/24	275	125
AVPA/AVHA30/36 & HVEA24	355	160
AVPA/AVHA42/48/60 & HVEA30/36 & HVESA36/42	535	245
HVEA49/60 & HVESA49/60	625	284
AVPA/AVHA72	680	309
ComPac With Economizer		
AVPA/AVHA12	185	84.1
AVPA24/AVHA20/24	286	130
AVPA/AVHA30/36 & HVEA24	375	170
AVPA/AVHA42/48/60 & HVEA30/36 & HVESA36/42	590	268
HVEA49/60 & HVESA49/60	640	291
AVPA/AVHA72	705	321
AVHSA72	740	336

Table 3. Shipping Weights for ComPac

1.5 General Operation

Refrigerant Cycle (Cooling Mode)

Marvair ComPac air conditioners use R-410A refrigerant in a conventional vapor-compression refrigeration cycle to transfer heat from air in an enclosed space to the outside. A double blower assembly blows indoor air across the evaporator. Cold liquid refrigerant passing through the evaporator is boiled into gas by heat removed from the air. The warmed refrigerant gas enters the compressor where its temperature and pressure are increased. The hot refrigerant gas condenses to liquid as heat is transferred to outdoor air drawn across the condenser by the condenser fan. Liquid refrigerant is metered into the evaporator to repeat the cycle.

Heating Mode

A wall-mounted thermostat controls the heating cycle of models which incorporate resistance heating elements. On a call for heat, the thermostat closes the heat relay to energize the indoor fan and the resistance elements. Except on units with the optional dehumidification kit, the compressor is locked out during the heating cycle. Please see Appendix A for instructions on field installing electric heaters.

Economizer Operation

The economizer is a regulated damper system with controls. The damper regulates the circulation of outside air into the enclosure (when the outdoor air conditions are suitable) to reduce the need for mechanical cooling, save energy, and extend compressor life.

Depending upon the options selected, the damper responds to the enthalpy of the outdoor air. On a call for cooling from a space thermostat, it operates as follows:

When the enthalpy of the outdoor air is below the set point, the outdoor air damper is proportionally open (and return air damper is proportionally closed) to maintain between 50°F and 56°F (10°C to 13°C) at the mixed/discharge air sensor. Integral pressure relief allows the indoor air to exit the shelter through the air conditioner.

When the enthalpy of the outdoor air is above the set point, the outdoor air damper closes to its minimum position. A call for cooling from the space thermostat brings on mechanical cooling.

A built-in adjustable minimum position potentiometer controls the amount of outdoor air admitted to meet minimum ventilation requirements.

1.6 Electronic Control Board Mode of Operation

Normal

24 VAC power must be continuously applied to “R” and “C”. Upon a call for cooling “Y” and with the high pressure switch (HPS) closed, the compressor will be energized. (Note: See the delay on make feature.) The compressor will remain energized during the 3 minute timed low pressure by-pass cycle. If the low pressure switch (LPS) is open after the 3 minute by-pass cycle, the compressor will de-energize.

Lock-out

If either of the fault conditions (LPS or HPS) occurs twice during the same call for cooling, the control board will enter into and indicate the lockout mode. In the lockout mode, the compressor is turned off. If there is a call for indoor air flow “G”, the blower remains energized, the alarm output is energized and the status LED will blink to indicate which fault has occurred. When the lockout condition is cleared, the unit will reset if the demand for the thermostat is removed or when the power is reset. With the control board, the user can now have either normally closed or normally open remote alarm dry contacts. ComPac® air conditioners are factory wired to be normally open.

Delay on Break

If the compressor is de-energized due to a loss of a cooling “Y” call or the first fault, the unit re-start will be delayed 3 minutes from the time the contactor is de-energized. (Note: There is no delay on break if the lockout condition is reset.)

Delay on Make

On initial power up only, the unit will wait 0.03 to 10 minutes from the cooling “Y” call before allowing the contactor to energize. The delay can be adjusted by the DOM wheel on the board. Factory recommended wait is 3 minutes.

Low Pressure By-Pass Time

When starting, the low pressure switch (LPS) fault condition will be by-passed for 3 minutes before the contactor is de-energized.

Post Purge

Upon a call for indoor airflow “G” the blower will energize immediately. When in the cooling mode, the blower will remain energized for 10 to 90 seconds (adjustable) after the compressor has been de-energized. The time period can be changed by fan purge wheel on the board. Factory setting is 90 seconds.

LED Indicator Lights

COLOR	TYPE	STATUS	DESCRIPTION
Green	Power	Constant On	24 VAC power has been applied
Red	Status	Constant On	Normal operation
Red	Status	1 Blink	High pressure switch has opened twice
Red	Status	2 Blinks	Low pressure switch has opened twice

Low Ambient Control

The low ambient control permits cooling when outdoor ambient temperatures are low. The control uses a reverse-acting high pressure switch to cycle the condenser fan motor according to liquid refrigerant pressure conditions. Switch closure and fan operation occurs when the pressure reaches 400 PSIG. The switch opens again when the refrigerant pressure falls to 290 PSIG. Therefore, the outdoor fan always starts after the compressor, and **it will cycle frequently during normal operation at low outdoor conditions.**

High Pressure Switch

The high pressure switch is mounted on the liquid line. It is electrically connected to a lockout circuit on the board which shuts down the system if the refrigerant pressure rises to 650 PSIG. This protects the unit if airflow through the condenser is blocked or if the outdoor fan motor fails.

Although the contacts of the high pressure switch close when the refrigerant pressure falls to approximately 450 PSIG, the system must be manually reset once the lockout circuit is activated. A manual reset is necessary to prevent harmful short-cycling. To reset switch, turn primary power off, then back on or turn thermostat system switch off, then back on.

Low Pressure Switch

The low pressure switch is mounted on the compressor suction line. It is designed to open if the refrigerant pressure drops to 40 PSIG; it resets when the pressure rises to 60 PSIG. The switch protects the unit if airflow through the indoor blower is impeded, if the blower motor fails, or if there is a loss of refrigerant.

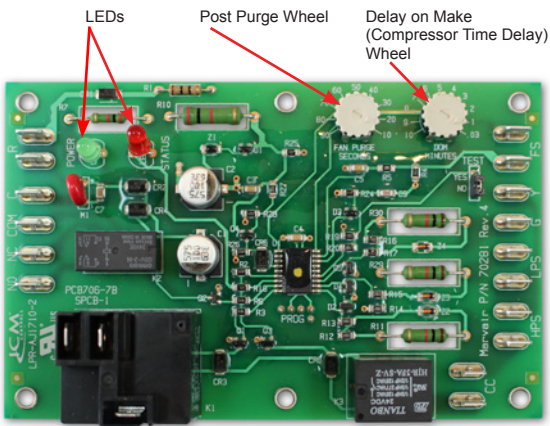

1.7 Optional Controls & Packages

Hard Start Kit

Used on single phase equipment to give the compressor higher starting torque under low voltage conditions. Generally not recommended on units with scroll compressors.

Extreme Duty Package (not available on AVPA12)

The Extreme Duty Package allows selected Marvair ComPac® air conditioners to operate in extremely cold and hot ambient conditions. The Extreme Duty Kit is always factory installed. Non-economizer ComPac air conditioners will operate from 0° F to 131° F (-18° to 55°C). Economizer equipped ComPac air conditioners will operate from -40° F to 131° F (-40° to 55°C).

The Extreme Duty Package includes a suction line accumulator, thermal expansion valve (TXV), crankcase heater, hard start kit, an auto reset, high pressure switch and an outdoor thermostat and fan cycle switch. The fan cycle control is standard on all ComPac air conditioners and operates based upon the liquid line pressure. The outside thermostat closes whenever the outside temperature is below 50°F (10°C) and opens when the outside temperature is 50° F (10°C) or higher. Whenever the temperature is below 50°F (10°C), the fan cycle switch is in the circuit; when temperatures are 50° F (10°C) or higher, the fan cycle switch is not in the circuit. The fan cycle control is used with a TXV to prevent excessive cycling or "hunting" of the TXV.

Protective Coating Packages

Typically only the non-economizer ComPac are used in corrosive environments, but the ComPac with an economizer is also available with corrosion protection. Two corrosion protection packages are offered- one for the condenser section (the Coastal Environmental package) and the other for the entire unit (the Coat-All Package).

The Coastal Environmental Package includes:

- Corrosion resistant fasteners
- Sealed or partially sealed condenser fan motor
- Protective coating applied to all exposed internal copper and metal in the condenser section
- Protective coating on the condenser coil (Luvata Insitu®) contains ES2 (embedded stainless steel pigment) technology.

The Coat all Package includes all of the above, plus:

- Protective coating on the evaporator coil (Luvata Insitu®) contains ES2 (embedded stainless steel pigment) technology
- Protective coating on exterior and interior components and sheet metal. (Note: the internal sheet metal which is insulated, bottom outside panel, and the internal control box are not coated)

Note: The AVPA12 is available with the protective coatings and corrosion resistant fasteners, but does not have a sealed condenser fan motor.

Hot Gas Bypass (Non-Economizer Models Only) *Not available on the AVPA12/24*

Used in specialty applications; i.e., Magnetic Resonance Imaging (MRI) buildings, to prevent magnetic voltage disturbance caused by compressor cycling. Two hot gas bypass option packages are available to allow operation to 20°F (-7°C) or minus 20°F (-29°C). Please refer to Hot Gas Bypass Application Bulletin for details.

Electric Reheat Dehumidification *Not available on the AVPA12*

A humidity controller allows electric heat and cooling to operate simultaneously. Marvair® air conditioners equipped with the dehumidification option allow the indoor humidity of the controlled environment to be maintained at or below a certain humidity set point. These units do not have the ability to add humidity to the building.

IMPORTANT

The electrical wire and breaker or fuses must be sized for simultaneous operation of the electric heater and the air conditioner. Refer to the data sticker on the unit or the appropriate Air Conditioner Product Data Sheet for the sizing information.

Dehumidification is achieved by operating mechanical cooling in conjunction with electric reheat. The strip heat is sized approximately to the sensible capacity of the total tonnage of the machine (i.e., on a 24,000 BTU unit the strip heat is sized at approximately 20,000 BTU). Because the strip heat is sized to the approximate sensible cooling capacity, only selected models are available.

Operation:

When the humidity rises above the set point on the humidity controller both mechanical cooling and electric reheat operate to temper the air and lower the humidity. If the temperature in the controlled environment rises above the set point of the thermostat and the unit is operating in the dehumidification mode, the call for cooling will override the call for dehumidification and the strip heat is disengaged until the thermostat is satisfied. This assures the environment temperature is maintained as first priority and humidity control is second.

In applications where a shelter has redundant air conditioning units and is controlled by a lead lag controller (CommStat Touch, CommStat 4, CommStat 3 HVAC Controller), most times the dehumidification option is only necessary on one of the two units. It is possible for one unit to be operating in the cooling mode while the unit with dehumidification is operating at the same time. If the cooling unit does not maintain the shelter temperature set point, the unit with dehumidification will go into the cooling mode. It does not matter whether the unit with dehumidification is the lead or lag unit.

Three Phase Voltage Monitor

Continuously measures the voltage of each of the three phases. The monitor separately senses low and high voltage, voltage unbalance including phase loss and phase reversal. An LED indicator glows when all voltages are acceptable. Automatically resets when voltages and phases are within operating tolerances. Not required on 1Ø units.

Dirty Filter Indicator *(Not Available on the AVPA12)*

A diaphragm type of indicator measures the air pressure on either side of the filter and when the pressure drops below the set point, a red LED is illuminated. The set point is adjustable.

Protective Coil Coatings

Either the condenser or evaporator coil can be coated, however, coating of the evaporator coil is not common. For harsh conditions, e.g., power plants, paper mills or sites where the unit will be exposed to salt water, the condenser coil should be coated. Note: Cooling capacity may be reduced by up to 5% on units with coated coils.

Thermal Expansion Valve

Available on all ComPac® air conditioners. Improves performance in hot ambient temperatures.

High Filtration (Not Available on the AVPA12)

Selected units are built with larger blowers/motors for use with higher efficiency filters with MERV ratings of 11, 13 and 14 when tested to ASHRAE 52.2. Units with economizers have a pre-filter on the outside air.

Lockable Disconnect Access Cover Plate

The access plate to the service disconnect switch can be equipped with a lockable cover.

Cold Climate Kit (AVPA24-72 and AVHA30-60 units)

Controls and components which allow the units to operate in extremely cold temperatures. The kit includes a suction line accumulator, thermal expansion valve (TXV), crankcase heater, hard start kit, and an outdoor thermostat and fan cycle switch. The fan cycle control is standard on all ComPac air conditioners and operates based upon the liquid line pressure. The outside thermostat opens whenever the outside temperature is below 50°F (10°C) and closes when the outside temperature is 50°F (10°C) or higher. Whenever the temperature is below 50°F (10°C), the fan cycle switch is in the circuit; when temperatures are 50°F (10°C) or higher, the fan cycle switch is not in the circuit. The outdoor thermostat is used with a TXV to prevent excessive cycling or “hunting” of the TXV.

Desert Duty (AVPA24-72 and AVHA30-60 units)

Controls and components which allow the units to operate in very hot ambients (131°F/55°C). Includes a thermal expansion valve, a sealed condenser fan motor, slotted base pan and a sealed control box. A closed loop design on the ComPac I units insures that no outside air is introduced into the shelter.

Cabinet Color and Material

Marvair ComPac air conditioners are available in three different cabinet colors -the standard Marvair beige, white and gray. The standard cabinet’s sides, top and front panels are constructed of 20 gauge painted steel. As an option, these panels can be built of 16 gauge steel in beige & gray or .050 stucco aluminum. When the 16 gauge painted steel or the aluminum is used, only the side, top and front panels are 16 gauge or aluminum. Contact your Marvair representative for color chips. The cabinet can also be constructed of type 316 stainless steel. Two stainless steel cabinet constructions are available- the complete cabinet, including most internal sheet metal or only the exterior sheet metal

1.8 Electrical Operation

The compressor and condenser fan are energized with a contactor controlled by a 24 VAC pilot signal. Some compressors incorporate an internal PTC crankcase heater that functions as long as primary power is available. The heater drives liquid refrigerant from the crankcase and prevents loss of lubrication caused by oil dilution. Power must be applied to the unit for 24 hours before starting the compressor.

The condenser (outside fan) motor is energized by the same contactor. However, the motor is cycled on and off by the low ambient control (see low ambient control 1.6).

The indoor evaporator fan motor is controlled by the fan purge on the electronic control board.

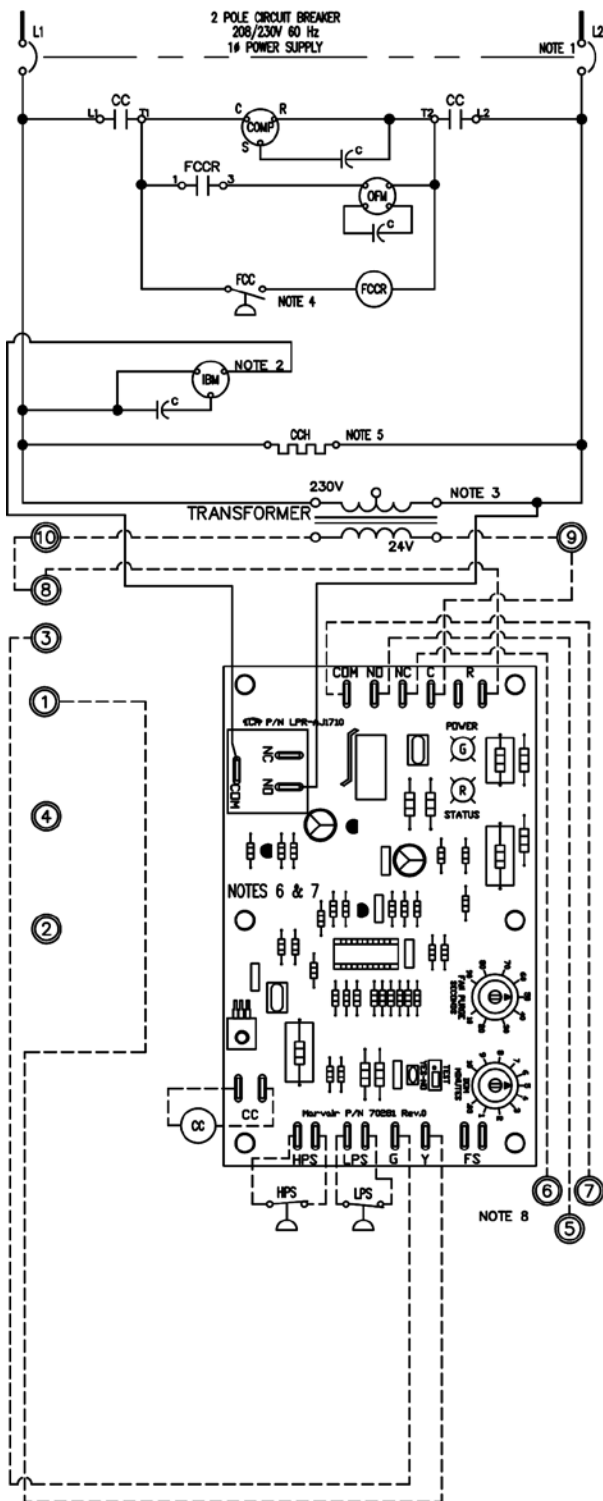

ELECTRICAL LEGEND:

C	CAPACITOR	LPS	LOW PRESSURE SWITCH
CC	COMPRESSOR CONTACTOR	OFM	OUTDOOR FAN MOTOR
CCH	CRANKCASE HEATER	PCB	PRINTED CIRCUIT BOARD
COMP	COMPRESSOR	XFMR	TRANSFORMER
FCC	FAN CYCLE CONTROL		
FCCR	FAN CYCLE CONTROL RELAY		
HPS	HIGH PRESSURE SWITCH		
IBM	INDOOR BLOWER MOTOR		

VOLTAGE LEGEND

—————	LINE VOLTAGE FACTORY
—————	LINE VOLTAGE FIELD
-----	LOW VOLTAGE FACTORY
-----	LOW VOLTAGE FIELD
-----	ALT. VOLTAGE (FIELD SPEC.)

COLOR CODE

BK	- BLACK	O	- ORANGE
BL	- BLUE	R	- RED
BR	- BROWN	Y	- YELLOW
G	- GREEN	WHT	- WHITE
BK/RED-BLACK, RED STRIPE			

GENERAL NOTES:

- 208/230 VOLT 60 Hz 1φ POWER SUPPLY. SEE DATA PLATE FOR AMPACITY & FUSE SIZE. OPTIONAL CKT BKR SHOWN.
- SPEED TAP - SEE MOTOR NAMEPLATE FOR WIRE COLOR.
- TRANSFORMER IS FACTORY WIRED FOR 230 VOLT OPERATION. FOR LOWER VOLTAGES, INTERCHANGE ORANGE AND RED LEADS. INSULATE UNUSED LEADS.
- ALTERNATE DEVICE IS NOT ADJUSTABLE AND HAS ORANGE LEADS.
- CRANKCASE HEATER MAY NOT BE REQUIRED ON ALL COMPRESSORS.
- COMPRESSOR TIME DELAY AND FAN PURGE DELAY ARE LOCATED ON THE PCB (PRINTED CIRCUIT BOARD) AND ARE ADJUSTABLE.
- THE (STATUS LED) WILL BLINK ONE TIME AFTER THE HPS (HIGH PRESSURE SWITCH) HAS OPENED TWICE AND THE UNIT WILL LOCKOUT. THE (STATUS LED) WILL BLINK TWICE AFTER THE LPS (LOW PRESSURE SWITCH) HAS OPENED TWICE AND THE UNIT WILL LOCKOUT.
- THE LOCKOUT CIRCUIT CONTACTS ARE N.O. BETWEEN TERMINALS 5 AND 7 OF THE LOW VOLTAGE TERMINAL BOARD AND N.C. BETWEEN TERMINALS 7 AND 6 OF THE LOW VOLTAGE TERMINAL BOARD.

Figure 1a. Typical Electrical Schematic - ComPac® (Non-Economizer), Model AVPA/AVHA

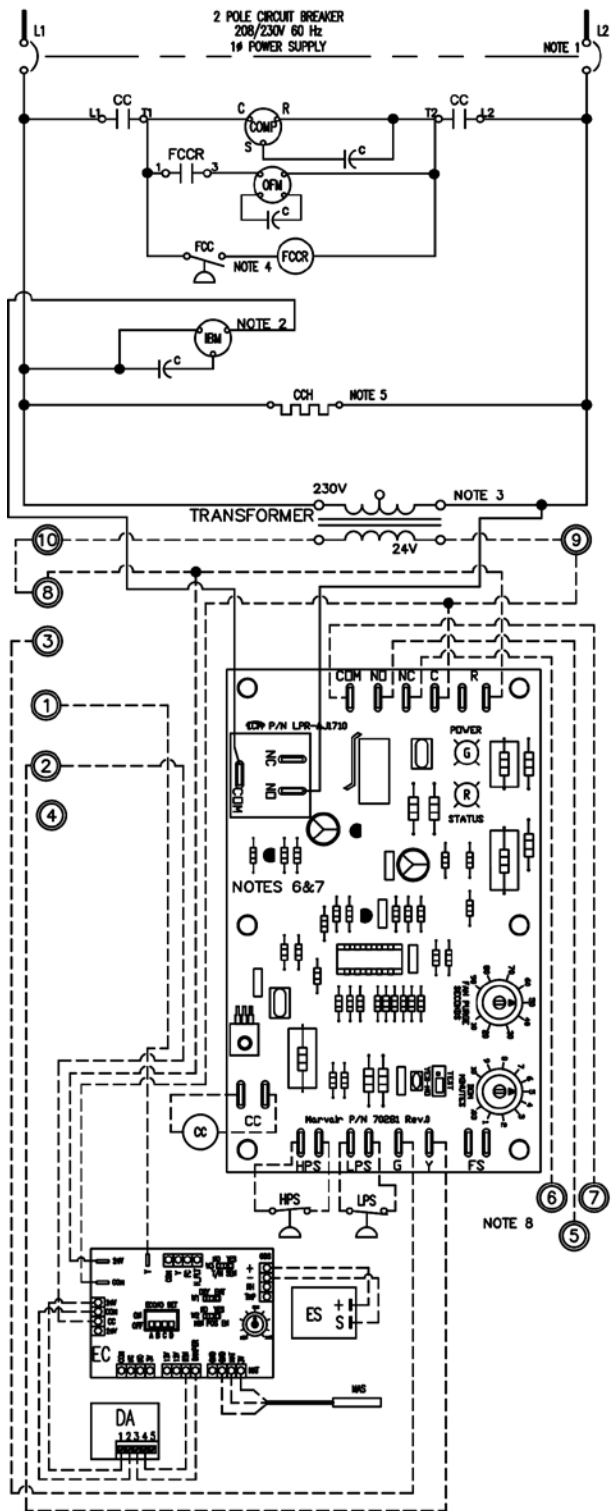

- ELECTRICAL LEGEND:**
- | | | | |
|------|-------------------------|------|-----------------------|
| C | CAPACITOR | LPS | LOW PRESSURE SWITCH |
| CC | COMPRESSOR CONTACTOR | MAS | MIXED AIR SENSOR |
| CCH | CRANKCASE HEATER | OFM | OUTDOOR FAN MOTOR |
| COMP | COMPRESSOR | PCB | PRINTED CIRCUIT BOARD |
| DA | DAMPER ACTUATOR | XFMR | TRANSFORMER |
| EC | ECONOMIZER CONTROLLER | | |
| ES | ENTHALPY SENSOR | | |
| FCC | FAN CYCLE CONTROL | | |
| FCCR | FAN CYCLE CONTROL RELAY | | |
| HPS | HIGH PRESSURE SWITCH | | |
| IBM | INDOOR BLOWER MOTOR | | |
- VOLTAGE LEGEND**
- | | | |
|-------|--------------|---------------|
| ————— | LINE VOLTAGE | FACTORY |
| ————— | LINE VOLTAGE | FIELD |
| ----- | LOW VOLTAGE | FACTORY |
| ----- | LOW VOLTAGE | FIELD |
| ----- | ALT. VOLTAGE | (FIELD SPEC.) |
- COLOR CODE**
- | | | | |
|--------|---------------------|-----|----------|
| BK | - BLACK | O | - ORANGE |
| BL | - BLUE | R | - RED |
| BR | - BROWN | Y | - YELLOW |
| G | - GREEN | WHT | - WHITE |
| BK/RED | - BLACK, RED STRIPE | | |

- GENERAL NOTES:**
- 208/230 VOLT 60 Hz 1φ POWER SUPPLY. SEE DATA PLATE FOR AMPACITY & FUSE SIZE. OPTIONAL CKT BKR SHOWN.
 - SPEED TAP - SEE MOTOR NAMEPLATE FOR WIRE COLOR.
 - TRANSFORMER IS FACTORY WIRED FOR 230 VOLT OPERATION. FOR LOWER VOLTAGES, INTERCHANGE ORANGE AND RED LEADS. INSULATE UNUSED LEADS.
 - ALTERNATE DEVICE IS NOT ADJUSTABLE AND HAS ORANGE LEADS.
 - CRANKCASE HEATER MAY NOT BE REQUIRED ON ALL COMPRESSORS.
 - COMPRESSOR TIME DELAY AND FAN PURGE DELAY ARE LOCATED ON THE PCB (PRINTED CIRCUIT BOARD) AND ARE ADJUSTABLE.
 - THE (STATUS LED) WILL BLINK ONE TIME AFTER THE HPS (HIGH PRESSURE SWITCH) HAS OPENED TWICE AND THE UNIT WILL LOCKOUT. THE (STATUS LED) WILL BLINK TWICE AFTER THE LPS (LOW PRESSURE SWITCH) HAS OPENED TWICE AND THE UNIT WILL LOCKOUT.
 - THE LOCKOUT CIRCUIT CONTACTS ARE N.O. BETWEEN TERMINALS 5 AND 7 OF THE LOW VOLTAGE TERMINAL BOARD AND N.C. BETWEEN TERMINALS 7 AND 6 OF THE LOW VOLTAGE TERMINAL BOARD.

Figure 1b. Typical Electrical Schematic - ComPac® (Economizer), Model AVPA/AVHA

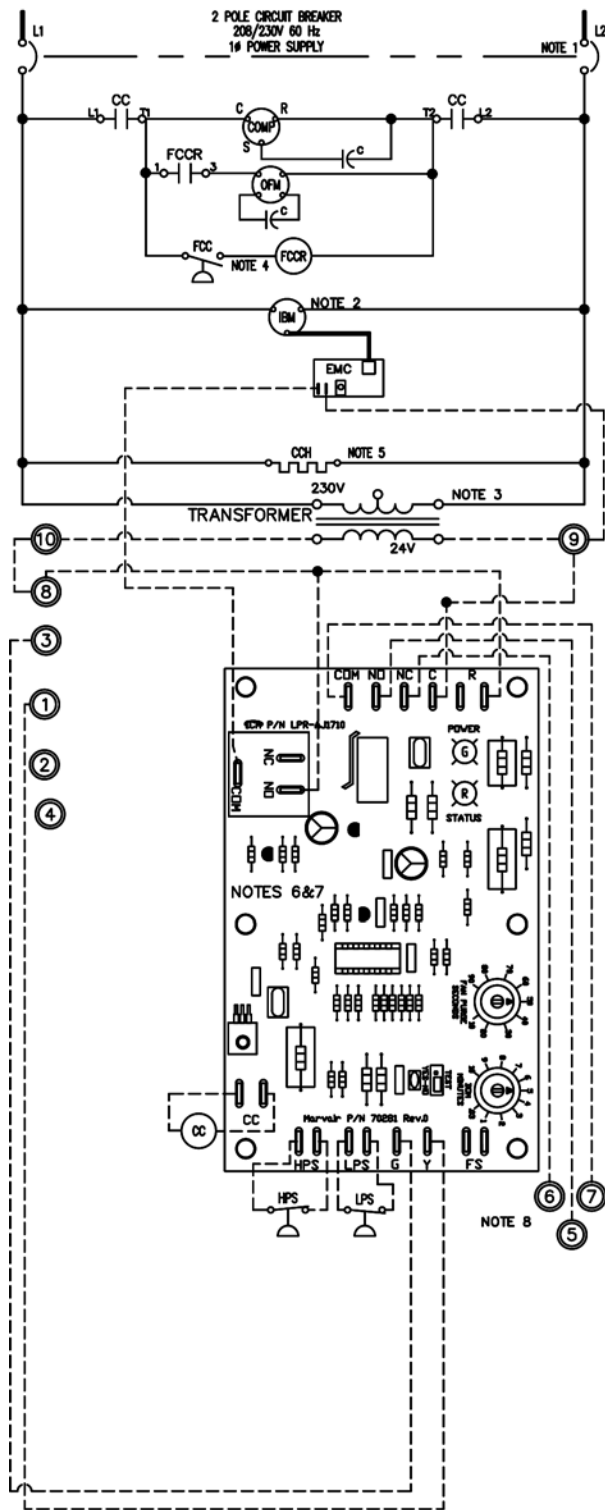

- ELECTRICAL LEGEND:**
- | | | | |
|------|--------------------------|------|-----------------------|
| C | CAPACITOR | LPS | LOW PRESSURE SWITCH |
| CC | COMPRESSOR CONTACTOR | OFM | OUTDOOR FAN MOTOR |
| CCH | CRANKCASE HEATER | PCB | PRINTED CIRCUIT BOARD |
| COMP | COMPRESSOR | XFMR | TRANSFORMER |
| EMC | ELECTRONIC MOTOR CONTROL | | |
| FCC | FAN CYCLE CONTROL | | |
| FCCR | FAN CYCLE CONTROL RELAY | | |
| HPS | HIGH PRESSURE SWITCH | | |
| IBM | INDOOR BLOWER MOTOR | | |
-
- VOLTAGE LEGEND**
- | | | |
|-----------|--------------|---------------|
| ————— | LINE VOLTAGE | FACTORY |
| ————— | LINE VOLTAGE | FIELD |
| ----- | LOW VOLTAGE | FACTORY |
| ----- | LOW VOLTAGE | FIELD |
| - - - - - | ALT. VOLTAGE | (FIELD SPEC.) |
-
- COLOR CODE**
- | | | | |
|--------|---------------------|-----|----------|
| BK | - BLACK | O | - ORANGE |
| BL | - BLUE | R | - RED |
| BR | - BROWN | Y | - YELLOW |
| G | - GREEN | WHT | - WHITE |
| BK/RED | - BLACK, RED STRIPE | | |

- GENERAL NOTES:**
- 208/230 VOLT 60 Hz 1φ POWER SUPPLY. SEE DATA PLATE FOR AMPACITY & FUSE SIZE. OPTIONAL CKT BKR SHOWN.
 - FACTORY PROGRAMMED ECM MOTOR.
 - TRANSFORMER IS FACTORY WIRED FOR 230 VOLT OPERATION. FOR LOWER VOLTAGES, INTERCHANGE ORANGE AND RED LEADS. INSULATE UNUSED LEADS.
 - ALTERNATE DEVICE IS NOT ADJUSTABLE AND HAS ORANGE LEADS.
 - CRANKCASE HEATER MAY NOT BE REQUIRED ON ALL COMPRESSORS.
 - COMPRESSOR TIME DELAY AND FAN PURGE DELAY ARE LOCATED ON THE PCB (PRINTED CIRCUIT BOARD) AND ARE ADJUSTABLE.
 - THE (STATUS LED) WILL BLINK ONE TIME AFTER THE HPS (HIGH PRESSURE SWITCH) HAS OPENED TWICE AND THE UNIT WILL LOCKOUT. THE (STATUS LED) WILL BLINK TWICE AFTER THE LPS (LOW PRESSURE SWITCH) HAS OPENED TWICE AND THE UNIT WILL LOCKOUT.
 - THE LOCKOUT CIRCUIT CONTACTS ARE N.O. BETWEEN TERMINALS 5 AND 7 OF THE LOW VOLTAGE TERMINAL BOARD AND N.C. BETWEEN TERMINALS 7 AND 6 OF THE LOW VOLTAGE TERMINAL BOARD.

Figure 1c. Typical Electrical Schematic - ComPac® (Non-Economizer), Model HVEA

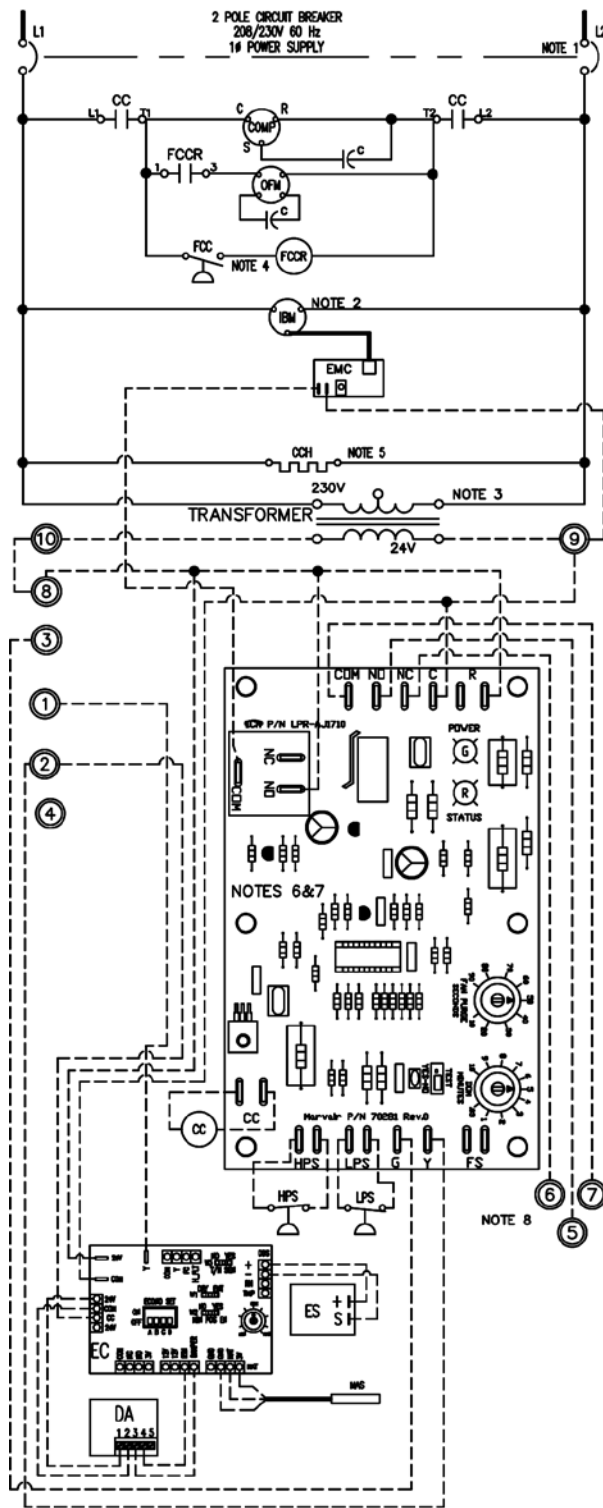

ELECTRICAL LEGEND:

C	CAPACITOR	LPS	LOW PRESSURE SWITCH
CC	COMPRESSOR CONTACTOR	MAS	MIXED AIR SENSOR
CCH	CRANKCASE HEATER	OFM	OUTDOOR FAN MOTOR
COMP	COMPRESSOR	PCB	PRINTED CIRCUIT BOARD
DA	DAMPER ACTUATOR	XFMR	TRANSFORMER
EC	ECONOMIZER CONTROLLER		
EMC	ELECTRONIC MOTOR CONTROL		
ES	ENTHALPY SENSOR		
FCC	FAN CYCLE CONTROL		
FCCR	FAN CYCLE CONTROL RELAY		
HPS	HIGH PRESSURE SWITCH		
IBM	INDOOR BLOWER MOTOR		

VOLTAGE LEGEND

—————	LINE VOLTAGE FACTORY
—————	LINE VOLTAGE FIELD
-----	LOW VOLTAGE FACTORY
-----	LOW VOLTAGE FIELD
-----	ALT. VOLTAGE (FIELD SPEC.)

COLOR CODE

BK	- BLACK	O	- ORANGE
BL	- BLUE	R	- RED
BR	- BROWN	Y	- YELLOW
G	- GREEN	WHT	- WHITE
BK/RED—BLACK, RED STRIPE			

GENERAL NOTES:

- 208/230 VOLT 60 Hz 1Φ POWER SUPPLY. SEE DATA PLATE FOR AMPACITY & FUSE SIZE. OPTIONAL CKT BKR SHOWN.
- FACTORY PROGRAMMED ECM MOTOR.
- TRANSFORMER IS FACTORY WIRED FOR 230 VOLT OPERATION. FOR LOWER VOLTAGES, INTERCHANGE ORANGE AND RED LEADS. INSULATE UNUSED LEADS.
- ALTERNATE DEVICE IS NOT ADJUSTABLE AND HAS ORANGE LEADS.
- CRANKCASE HEATER MAY NOT BE REQUIRED ON ALL COMPRESSORS.
- COMPRESSOR TIME DELAY AND FAN PURGE DELAY ARE LOCATED ON THE PCB (PRINTED CIRCUIT BOARD) AND ARE ADJUSTABLE.
- THE (STATUS LED) WILL BLINK ONE TIME AFTER THE HPS (HIGH PRESSURE SWITCH) HAS OPENED TWICE AND THE UNIT WILL LOCKOUT. THE (STATUS LED) WILL BLINK TWICE AFTER THE LPS (LOW PRESSURE SWITCH) HAS OPENED TWICE AND THE UNIT WILL LOCKOUT.
- THE LOCKOUT CIRCUIT CONTACTS ARE N.O. BETWEEN TERMINALS 5 AND 7 OF THE LOW VOLTAGE TERMINAL BOARD AND N.C. BETWEEN TERMINALS 7 AND 6 OF THE LOW VOLTAGE TERMINAL BOARD.

Figure 1d. Typical Electrical Schematic - ComPac® (Economizer), Model HVEA

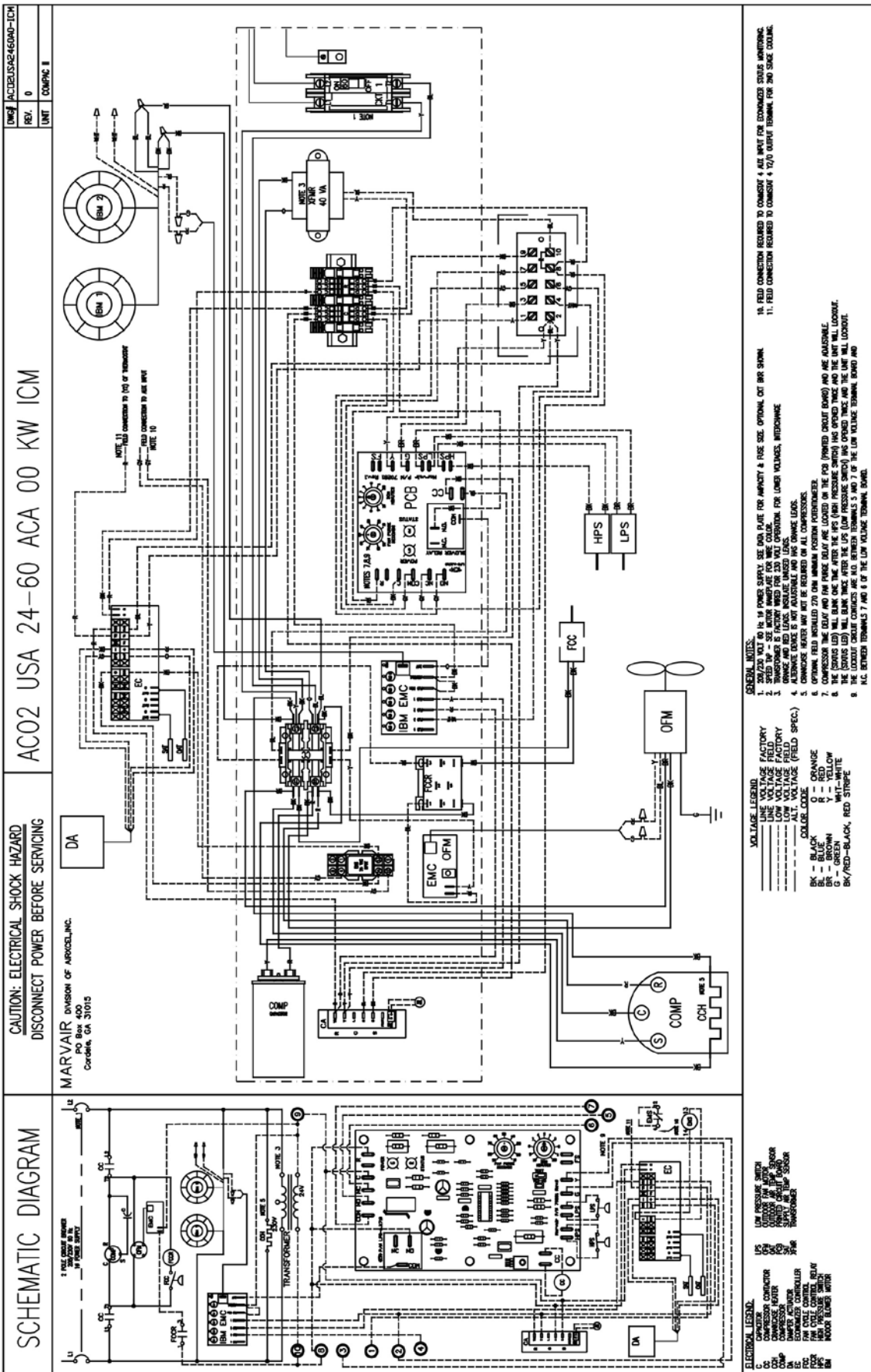

Figure 1e. Typical Electrical Schematic - ComPac® (Economizer), Model HVESA (Alternate Construction)

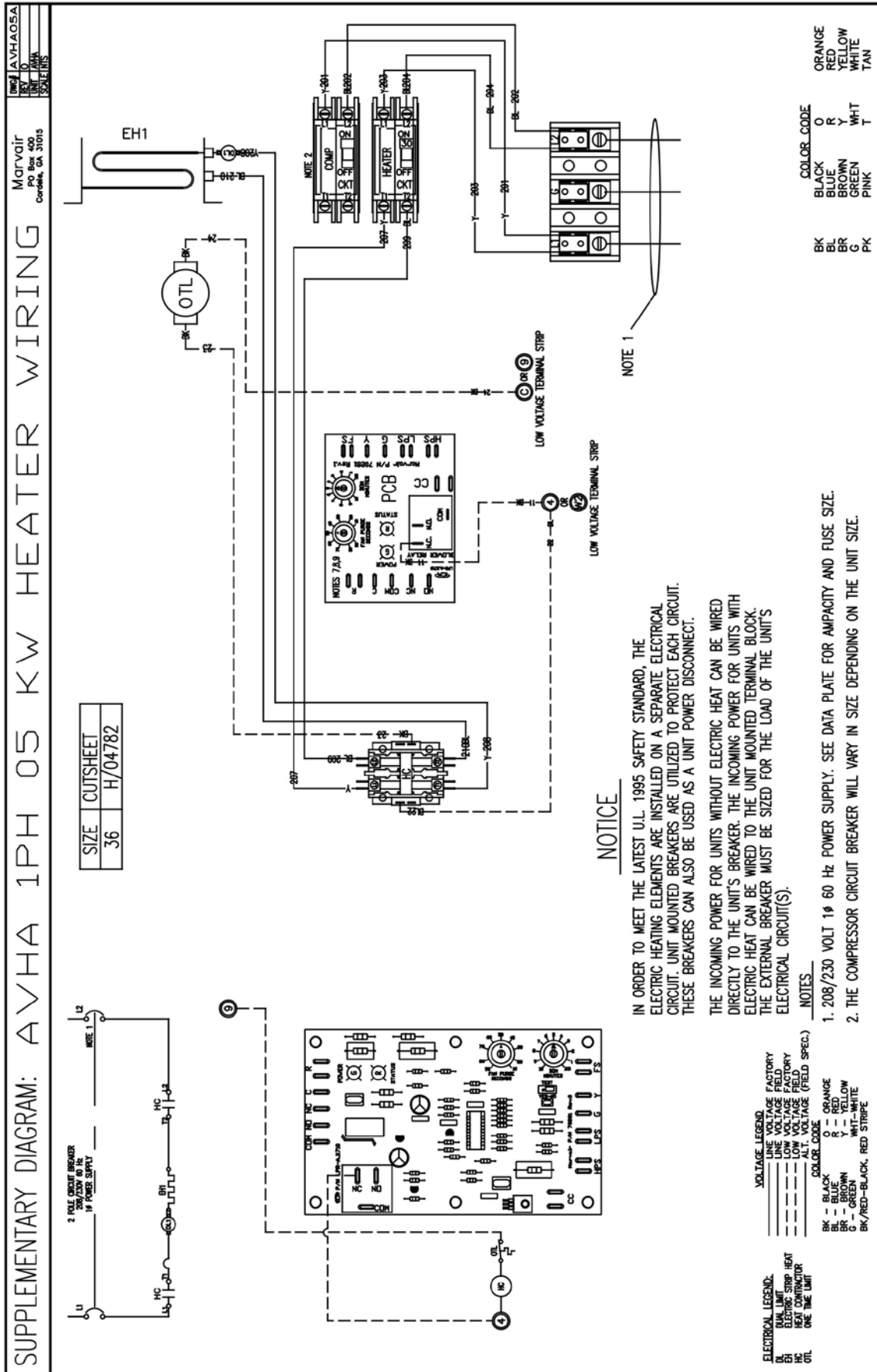

Figure 1f. Typical Electrical Schematic - ComPac® (Economizer), Model HVESA (Alternate Construction)

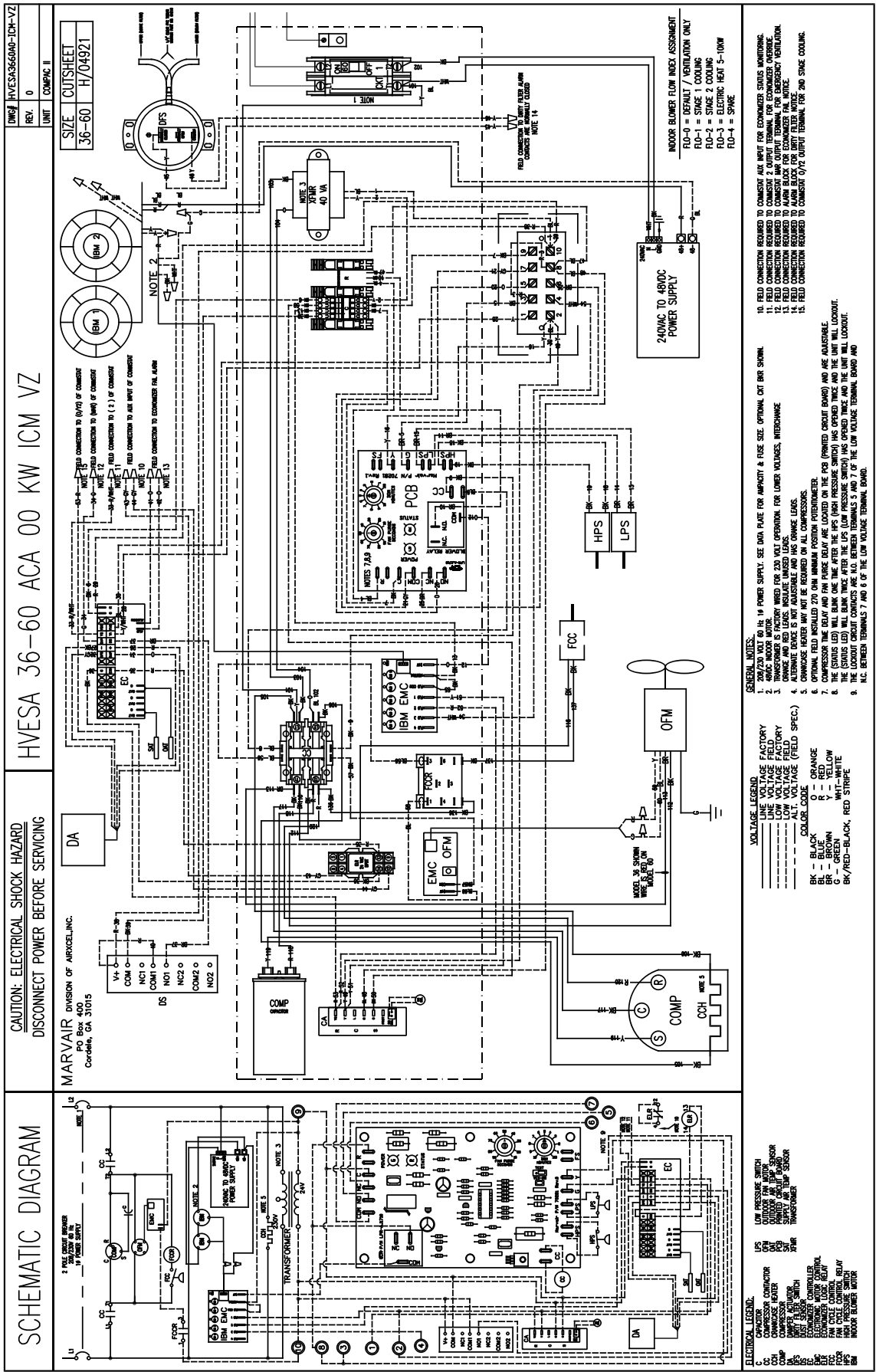

Figure 1g. Typical Electrical Schematic - ComPac® (Economizer), Model AVHSA (Alternate Construction)
 Marvaair ComPac Installation & Operation Manual
 08/2018 Rev.19

1.9 Economizer Components (Economizer Equipped ComPac Models Only)

Damper Actuator:

The damper actuator is a 24V motor that modulates the position of the damper blade. It is capable of driving a full 90 degrees within 90 seconds. The assembly has a spring return to close the damper during power outage.

Economizer changeover control (W1 Jumper)

The economizer can be controlled by either an enthalpy sensor or a dry bulb sensor. On a call for cooling from the wall-mounted thermostat, if outdoor conditions are suitable, the sensor will open the damper and admit outside air (i.e., economizer free cooling). If the outdoor ambient is too hot or humid (enthalpy sensor only), the sensor will place the actuator in the closed or minimum open position and activate mechanical cooling. The compressor is locked-out during the economizer cooling mode.

During the testing of the air conditioner at the factory, the control board has been configured for the sensor in the air conditioner. There should be no need to change the sensor configuration. If an enthalpy sensor is being used, pins 1 & 2 should be jumpered on the board. If a dry bulb sensor is being used, pins 2 & 3 should be jumpered. See item 1 in Figure 4 for the location of this jumper.

Economizer changeover control setting - Enthalpy Sensor

The enthalpy sensor responds to the total heat content of the outdoor air to provide the changeover to outside air for free cooling. The control board must be configured for proper operation of the economizer by selecting the desired changeover temperature. The desired temperature is selected by four dip switches on the board. See item 9 in Figure 4 for the location of the dip switches.

1. Selecting the set point for the enthalpy sensor. On the board there are four dip switches – 1, 2, 3 & 4 - that determine the ambient temperature at which the economizer damper opens. These dip switches correspond to the following temperatures:

DIP Switch #	Previous Honeywell controller setting	Temperature °F/°C
All 4 Switches Down	A	73°/23.8°C
1	A	73°/23.8°C
2	B	70°F/21.1°C
3	C	67°F/19.4°C
4	D	63°F/17.2°C

2. Gently push the dip switch UP to select the desired set point temperature. The factory setting is for dip switches number 1, 2, & 3 to be in the Down position and #4 to be in the Up position. With dip switch #4 in the Up position, the economizer damper will begin to open when the ambient temperature is 63°F/17.2°C.
3. Only one switch should be in the Up position.

Note: having all four switches in the down position is the same setting as having the #1 switch in the Up position.



Sever hazard. The economizer contains moving parts capable of causing serious injury or death. Disconnect power before removing the covering panel.

Economizer changeover control – Dry Bulb Sensor

The dry bulb sensor only responds to the dry bulb temperature of the outside air and ignores the humidity. The sensor has eight set points. The factory setting is 58°F (14.5°C). These set points can be changed by moving the dip switches on the top of the dry bulb sensor. See Fig. 2.



Figure 2. Dry Bulb Sensor

Once either the enthalpy or dry bulb sensor has determined that the outside air is suitable for cooling, the damper will open. The mixed air sensor will limit the air temperature delivered to the space by modulating the damper blade to mix warm indoor air with cooler outdoor air to provide a constant 50°F to 56°F (10°C to 13.5°C)

Mixed Air Sensor:

The mixed air sensor is a thermistor mounted on a bracket adjacent to the right side of the blower assembly. The thermistor senses the air temperature entering the structure, and provides a signal to the economizer controller for modulating the position of the damper.

Minimum Position Potentiometer (W2 jumper):

The potentiometer controls the amount of outside air introduced in the building when the economizer damper closes or the air conditioner is Off or in Mechanical Cooling. The factory setting is for the damper to close completely when the unit is off or in Mechanical Cooling. (Pins 1 & 2 are jumpered)

If outside air is desired during mechanical cooling or whenever the indoor blower is running, jumper pins 2 & 3. Refer to item 8 in Figure 4 for the location of the jumper.

If the potentiometer is enabled, the next step is to select how much outside air should be brought into the building.

The potentiometer is adjustable from 0% to 100%. Setting the potentiometer to MIN means that the damper will close completely and NO outside air will be brought into the building. Setting the potentiometer to MAX means that the damper stays in the full OPEN position at all times. Factory setting is 50%.

Brand of Sensor Selection (W3 jumper)

Honeywell enthalpy and dry bulb sensors are currently the only brand of sensors used in the air conditioners. Jumper W3 allows us to use alternative brands at a future date. On all current air conditioners, pins 1 & 2 are jumpered on W3. See item 4 in Figure 4.

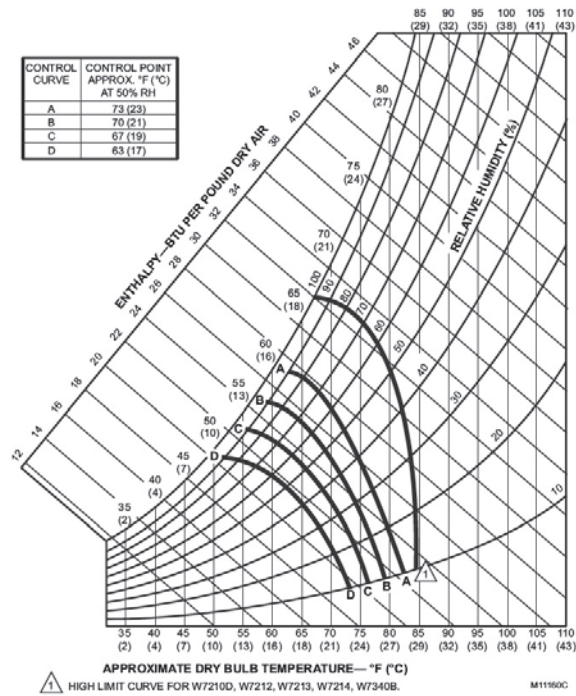

Figure 3. Enthalpy Sensor Temperature Control Points

Marvoir Economizer Controller

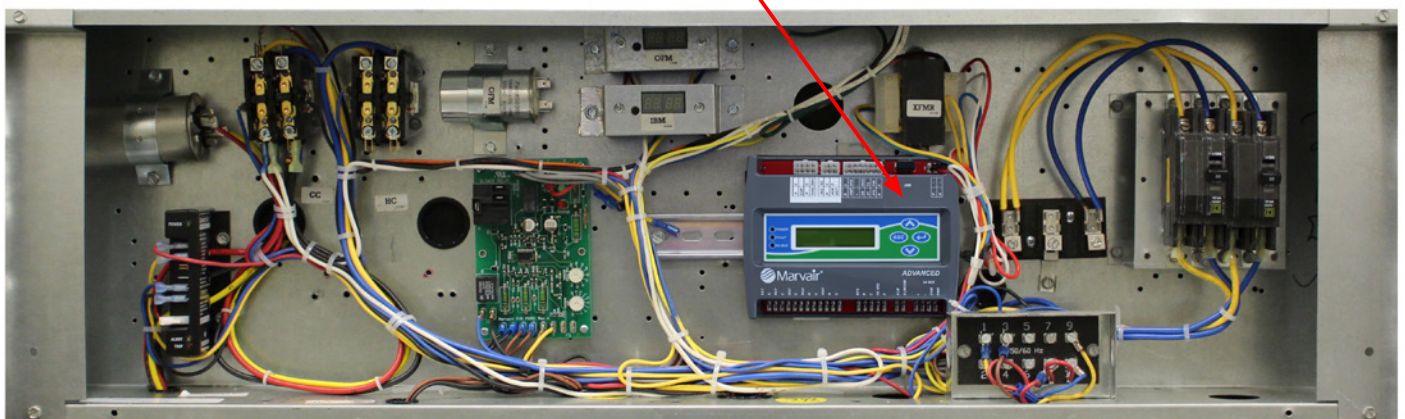
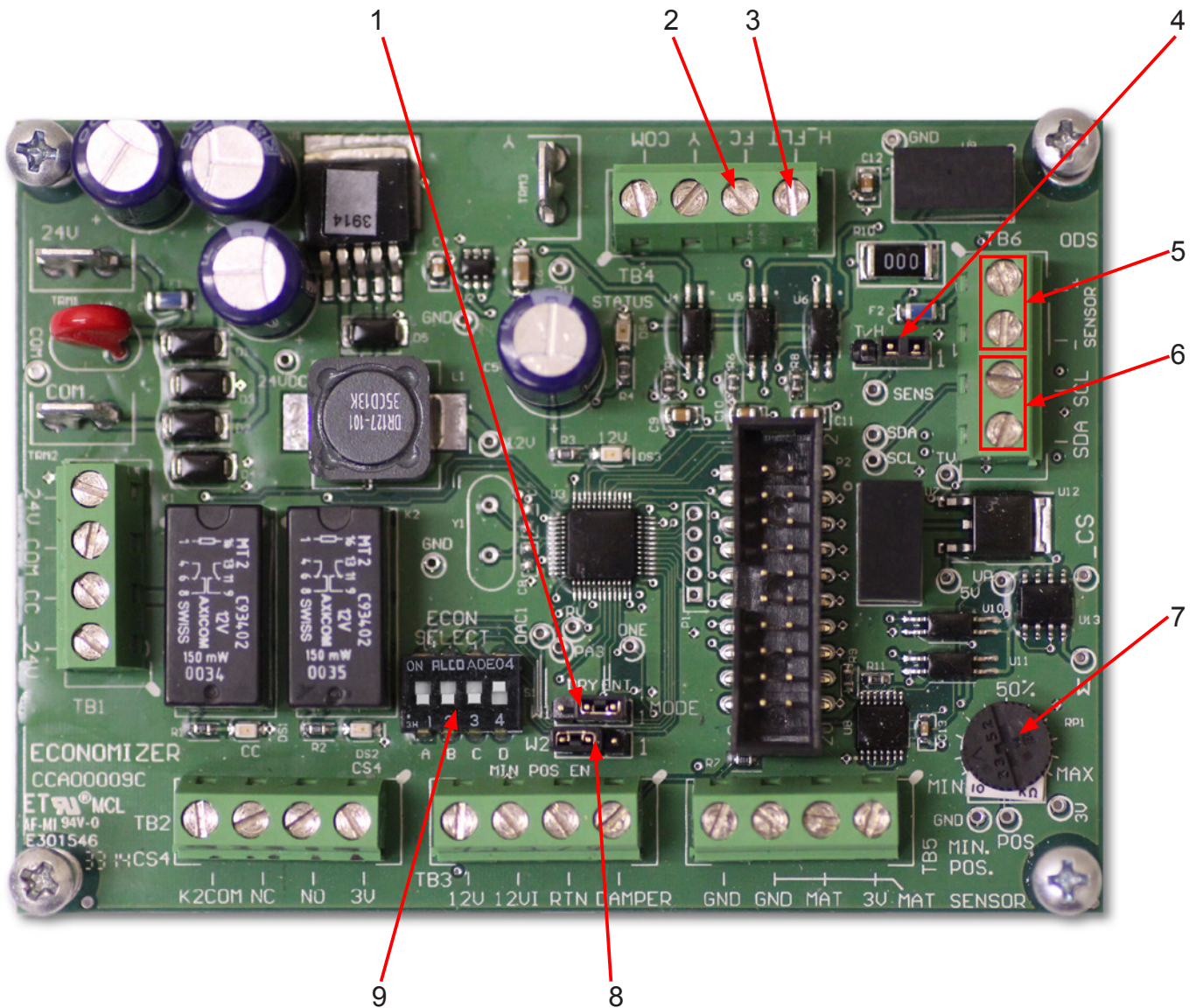

Figure 4. Electrical Controls, HVESA Alternate Construction



- | | | |
|--|---|--|
| <p>1. W1 Economizer Sensor Selector
Jumper Pins 1 & 2 for enthalpy sensor
Jumper Pins 2 & 3 for dry bulb sensor</p> <p>2. Field connection from
CommStat 4 (2) terminal</p> <p>3. Field connection from CommStat 4
(MAR) terminal</p> | <p>4. W3 Sensor Brand Selector
Jumper Pins 1 & 2 for Honeywell sensor
Jumper Pins 2 & 3 for Prism sensor</p> <p>5. For Honeywell sensors</p> <p>6. For Prism sensors</p> | <p>7. Minimum Position Potentiometer
0% to 100%. Factory setting is 50%.</p> <p>8. W2 Minimum Position Potentiometer Jumper
Jumper Pins 1 & 2 to Disable (Factory setting)
Jumper pins 2 & 3 to Enable</p> <p>9. Enthalpy Dip Switches
Set points are same as previous
Honeywell controller.
Factory setting is 4 (63°F/17.2°)
1=A (73°F/23.8°C) 2=B (70°F/21.1°C)
3=C (67°F/19.4°C) 4=D (63°F/17.2°)</p> |
|--|---|--|

Figure 5. Economizer Control Board

Chapter 2 Installation



WARNING

Failure to observe and follow Warnings and Cautions and these Instructions could result in death, bodily injury or property damage. Read this manual and follow its instructions and adhere to all Cautions and Warnings in the manual and on the A/C unit.

2.1 Equipment Inspection

Concealed Damage

Inspect all cartons and packages upon receipt for damage in transit. Remove cartons and check for concealed damage. **Important: keep the unit upright at all times.** Remove access panels and examine component parts. (Note: the "L"-shaped bottom bracket is screwed to the shipping pallet, against the air conditioner. Remove it before replacing the side screen). Inspect refrigerant circuit for fractures or breaks. The presence of refrigerant oil usually indicates a rupture. If damage is apparent, immediately file a claim with the freight carrier.

Units that have been turned on their sides or tops may have concealed damage to compressor motor mounts or to the oil system. If the unit is not upright, immediately file a claim for concealed damages and follow these steps:

1. Set unit upright and allow to stand for 24 hours with primary power turned on.
2. Attempt to start the compressor after 24 hours.
3. If the compressor will not start, makes excessive noise, or will not pump, return the unit to the freight carrier.

2.2 Installation Requirements

General

1. Inspect unit for completeness. Check for missing parts (e.g. hardware). Refer to the installation kit information in section 2.3.
2. Remove access panels and check for loose wires. Tighten screw connections.
3. Complete and mail the warranty registration card.

You must consider all of the following when choosing the installation site:

1. **Noise.** Install the unit so that the least amount of noise will be transmitted to inhabited spaces.
2. **Condensate Drainage.** Condensate produced during operation must be discharged to a suitable drain.
3. **Placement.**
 - A) Place the unit in a shaded area, if possible.
 - B) Install it above ground for protection against flooding.
 - C) The unit exhausts air. Be sure that the airflow is not impeded by shrubbery or other obstructions.
 - D) When installing multiple units, please note the recommended clearances noted in Table 4.
4. **Airflow Requirements:**

Note the maximum static pressure (Table 6). Keep duct lengths as short as possible. Do not obstruct airflow through the unit.

Duct work should be designed and installed in accordance with *all* applicable safety codes and standards. Marvair® strongly recommends referring to the current edition of the National Fire

Protection Association Standards 90A and 90B *before* designing and installing duct work. The duct system must be engineered to insure sufficient air flow through the unit to prevent over-heating of the heater element. This includes proper supply duct sizing, sufficient quantity of supply registers, and adequate return and filter areas. Duct work must be of correct material and must be properly insulated. Duct work must be constructed of galvanized steel with a minimum thickness of .019 inches. Duct work must be firmly attached, secured, and sealed to prevent air leakage. See section 2.4 for additional duct work requirements.

5. **Clearances:**

Note the minimum clearances required for proper operation and service.

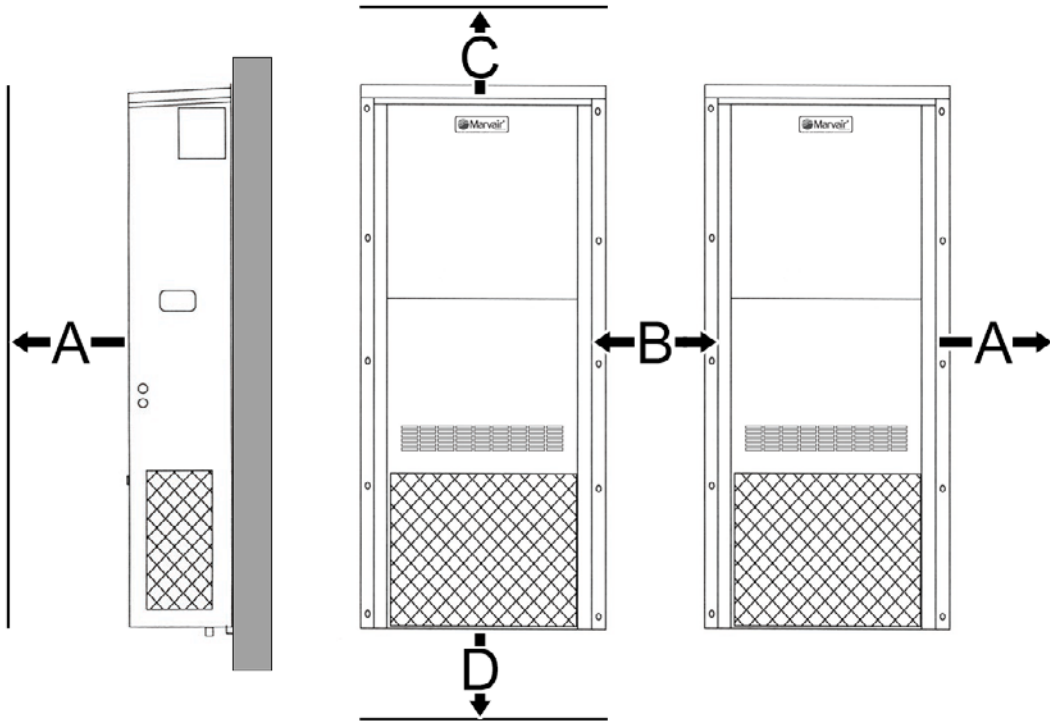

MODEL	MIN. CLEARANCE AROUND SIDES (SINGLE UNIT)	MIN. CLEARANCE BETWEEN UNITS (TWO UNITS)	MIN. SPACE ABOVE UNIT	MIN. SPACE BELOW UNIT
	A	B	C	D
12	24 inches (76 cm)	18 inches (46 cm)	24 inches (61 cm)	6 inches (15 cm)
20/24	30 inches (76 cm)	18 inches (46 cm)	24 inches (61 cm)	6 inches (15 cm)
30/36	30 inches (76 cm)	18 inches (46 cm)	24 inches (61 cm)	6 inches (15 cm)
42/48/60	30 inches (76 cm)	30 inches (76 cm)	24 inches (61 cm)	6 inches (15 cm)
72	30 inches (76 cm)	30 inches (76 cm)	12 inches (31 cm)	6 inches (15 cm)

Table 4. Minimum Clearances

6. **Codes:**

Make sure your installation conforms to all applicable electrical, plumbing, building, and municipal codes. Some codes may limit installation to single story structures.

7. **Electrical Supply:**

The power supply must have the appropriate voltage, phase, and ampacity for the model selected. Voltage must be maintained above minimum specified values listed below. Refer to the data sticker on the unit for ampacity requirements.

Electrical Rating Designations*	A	C	D
Nominal Voltage	208/230	208/230	460
Phase	1	3	3
Minimum Voltage	197	197	414
Maximum Voltage	253	253	506

* Letters refer to model number code designations. Refer to page 5.

Table 5. Voltage Limitations

2.3 Installation Materials

Installation Kits

Marvair ComPac units are shipped with one 12 Ga. "L" shaped bottom bracket. If you have not yet unpacked the unit, follow the instructions in section 2.1. All units have built-in full length mounting flanges. Therefore, use of mounting brackets is not required.

Kit Components:

1. One 12 Ga. "L"-shaped bottom bracket. Note: The AVPA12 does not require a bottom bracket.

Accessories:

The package may include other factory-supplied items (optional) as follows on the next page:

P/N	Description
K/10439	CommStat Touch HVAC Controller, Solid State Lead/Lag Controller w/Remote Access
S/07846	CommStat 4 HVAC Controller, Solid State Lead/Lag Controller
S/04581	CommStat 3 HVAC Controller, Solid State Lead/Lag Controller
50123	Digital thermostat. 1 stage heat, 1 stage cool. 7 day programmable. Fan switch: Auto & On. Auto-change over. Keypad lockout. Non-volatile program memory.
50107	Digital thermostat. 2 stage heat, 2 stage cool. 7 day programmable. Fan switch: Auto & On. Auto-change over. Status LED's. Backlit display. Programmable fan. Non-volatile program memory.
92379	17" x 17" Combination Aluminum Supply and Return Grille for the AVPA12 ComPac II units (with economizer). Requires S/09392 (17" x 17") wall sleeve.*
80681	26" x 17" Combination Aluminum Supply and Return Grille for the AVPA12 ComPac II units (with economizer). Requires S/01784 (26" x 17") wall sleeve.* *Note: a wall sleeve is required for proper installation and operation.
80682	17" x 5" Aluminum Double Deflection Supply Air Grille for AVPA12 ComPac I
92352	17" x 10" Aluminum Return Air Grille for AVPA12 ComPac I
80683	17" x 10" Aluminum Return Air Filter Grille for AVPA12 ComPac I
80674	VPG - 20S, 20" x 8" Adjustable, Aluminum, Double Deflection Supply Grill for AVPA24
80675	VPG - 30S, 28" x 8" Adjustable, Aluminum, Double Deflection Supply Grill for AVPA/AVHA30-36 and HVEA24
80676	VPG - 40S, 30" x 10" Adjustable, Aluminum, Double Deflection Supply Grill for AVPA42-48-60-72, AVHA42-48-60 and HVEA30-36-42-49-60
80677	VPG - 20R, 20" x 12" Aluminum Return Grill for AVPA24/AVHA20/24
80678	VPG - 30R, 28" x 14" Aluminum Return Grill for AVPA/AVHA30-36 and HVEA24
80679	VPG - 40R, 30" x 16" Aluminum Return Grill for AVPA42-48-60-72, AVHA42-48-60 and HVEA30-36-42-49-60

Additional Items Needed:

Additional hardware and miscellaneous supplies (not furnished by Marvair®) are needed for installation. For example, the list below contains approximate quantities of items typically needed for mounting a unit on a wood frame wall structure. Concrete or fiberglass structures have different requirements.

- (10) **3/8" carriage head mounting bolts** for unit mounting flanges. The length needed is typically the wall thickness plus one inch.
- (20) **3/8" washers**
- (10) **3/8" hex nuts**
- (6) **3/8" x 2-1/2" lag screws** for bottom bracket
- **Silicone Sealer** to seal around cracks and openings
- **Minimum 5 conductor low voltage multicolored wire cable** (i.e. thermostat wire)
- **Appropriate electrical supplies** such as **conduit, electrical boxes, fittings, wire connectors,** etc.
- **High voltage wire**, sized to handle the MCA (minimum circuit ampacity) listed on the data plate.
- **Over-Current Protection Device** sized in accordance with the MFS (maximum fuse size) listed on the unit data plate.

WARNING **FIRE HAZARD**

Improper adjustment, alteration, service, maintenance or installation could cause serious injury, death and/or property damage.

Installation or repairs made by unqualified persons could result in hazards to you and others. Installation MUST conform with local codes or, in the absence of local codes, with codes of all governmental authorities have jurisdiction.

The information contained in this manual is intended for use by a qualified service agency that is experienced in such work, is familiar with all precautions and safety procedures required in such work, and is equipped with the proper tools and test instruments.

2.4 Porting and Duct Work

General Information

Note: The following instructions are for general guidance only. Due to the wide variety of installation possibilities, specific instructions will not be given. When in doubt, follow standard and accepted installation practices, or contact Technical Support for additional assistance.

Wall Openings (AVPA12 ComPac I air conditioner and all AVPA24-72, all AVHA30-60 and all HVEA and HVESA air conditioners)

Measure the dimensions of the supply and return ports on the unit.

Cut the openings in the exterior wall for the supply and return. **IMPORTANT: All units with electric heat must have 1" (25.4mm) clearance on all four sides of the supply outlet duct flange on the unit. The 1" (25.4mm) clearance must extend on all sides of the supply duct for the first 3 feet (1 meter) from the unit.**

IMPORTANT: Marvair® requires a minimum of 1" (25.4mm) from the surface of any supply ducts to combustible material for the first 3 feet (1 meter) of the duct.

Wall Openings (AVPA12 ComPac II air conditioners with the factory installed economizer)

The back panel of the one ton ComPac air conditioner with the factory installed economizer is designed to have a single opening for the supply and return air. From the factory, the back panel is configured for a 19" x 19" (483 mm x 483 mm) opening, but can be easily changed in the field for a 28" x 19" (711 mm x 483 mm) opening. Note: the opening is larger than the wall sleeve to allow a one inch clearance on all four sides of the wall sleeve to any combustible material. This clearance is **required** per National Fire Protection Association (NFPA) standards 90A & 90B for any unit with electric heat.

To change the back panel to use with a 28" x 19" (711 mm x 483 mm) opening, see the instructions below.

Changing the back panel for use with a 17" (432 mm) wide wall sleeve 19" (483 mm) wide opening).

Note: Changing the back panel must be done before the unit is mounted on the enclosure.

1. When facing the supply and return air opening, locate the side duct flanges on either side of the opening. Each flange is held in position with four screws, two on the side, one at the top and one at the bottom.
2. Remove the screws and slide the duct flange out so that the holes in the duct flange aligns with the holes for the larger opening.
3. Replace the eight screws – four on each duct flange.

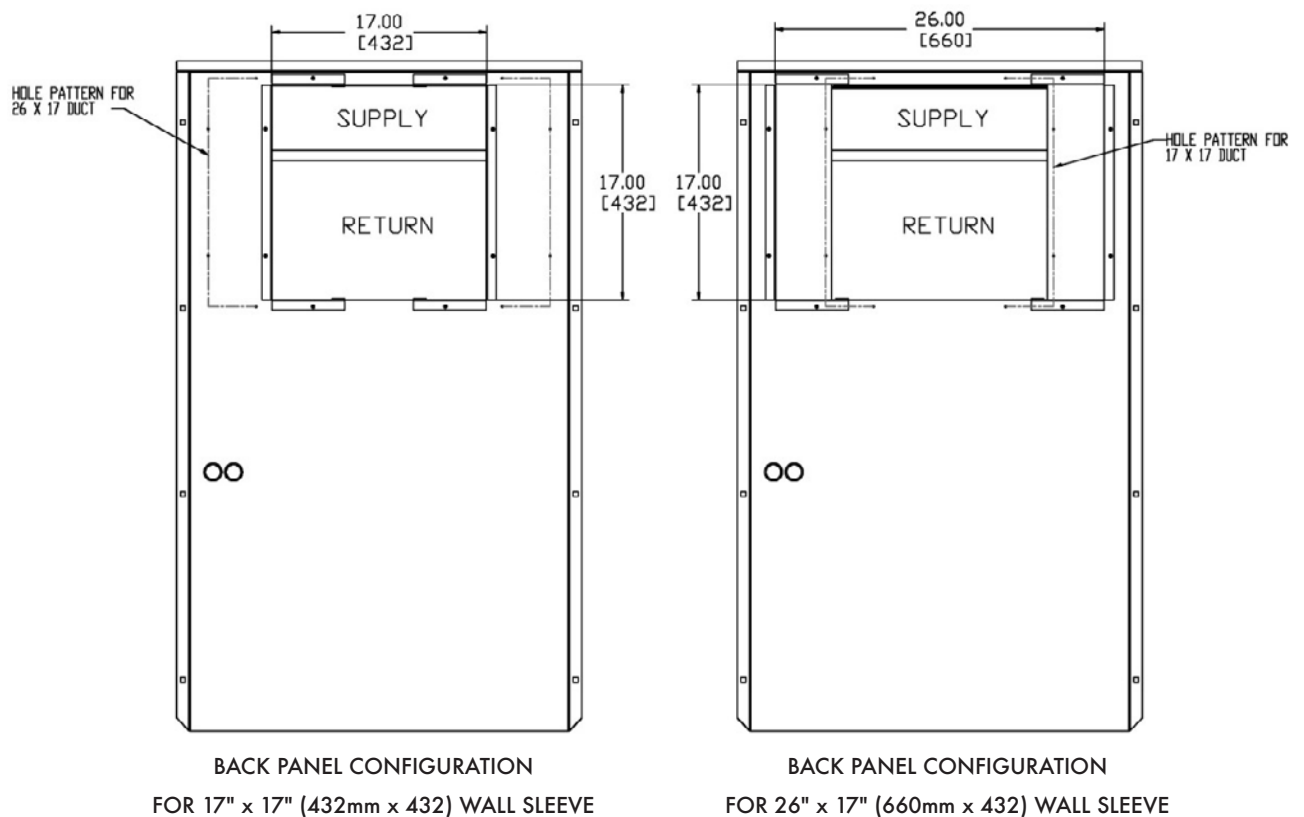

Figure 6. Back Panel Configuration for ComPac® II AVPA12 Air Conditioners

Wall Sleeve for one ton ComPac® air conditioners with an economizer

A wall sleeve is required for all installations of the one ton ComPac air conditioner if equipped with an economizer. The wall sleeve has a horizontal divider panel to separate the supply and return air. If the opening is 19" x 19" (483 mm x 483 mm) the wall sleeve, part number S/09392 is required. The S/09392 wall sleeve has outside dimensions of 17" x 17" (432 mm x 432 mm). If the opening is 28" x 19" (711 mm x 483 mm), the wall sleeve, part number S/01784 is required. The S/01784 wall sleeve has outside dimensions of 26" x 17" (660 mm x 432 mm).

For all air conditioners with electric heat, the wall sleeve **MUST** have 1” (25.4 mm) clearance around all four sides of the opening. Attach the perimeter flange of the wall sleeve to the framed opening with appropriately sized screws. Since electric heat can be added after the unit has been installed, Marvair recommends that all installations have the 1” (25.4 mm) clearance around the wall sleeve.

When installing the wall sleeve, the supply opening must be on top. The supply opening is smaller than the return air opening.

Combination Supply and Return Grille for one ton ComPac air conditioners with an economizer

A combination supply and return air grille is required for all installations of the one ton ComPac air conditioner if equipped with an economizer. If the opening is 19” x 19” (483 mm x 483 mm), the grille, part number 92379, must be used. If the opening is 28” x 19” (711 mm x 483 mm) the grille, part number 80681, must be used. Attach the combination supply and return grille to the wall sleeve, using the holes in the grille’s flange. Pilot holes must be drilled in the flange of the wall sleeve.

Wall Opening	Dimensions of Wall Sleeve	P/N of Wall Sleeve	P/N of Grille
19” x 19” (483 mm x 483 mm)	17” x 17” (432 mm x 432 mm)	S/09392	92379
28” x 19” (711 mm x 483 mm)	26” x 17” (660 mm x 432 mm)	S/01784	80681

Ducting

Extensions should be cut flush with the inside wall for applications without duct work.

Applications using duct work should be designed and installed in accordance with *all* applicable safety codes and standards. Marvair® strongly recommends referring to the current edition of the National Fire Protection Association Standards 90A and 90B *before* designing and installing duct work. The duct system must be engineered to insure sufficient air flow through the unit to prevent over-heating of the heater element. This includes proper supply duct sizing, sufficient quantity of supply registers, adequate return and filter area. Ductwork must be of correct material and must be properly insulated. Duct work must be constructed of galvanized steel with a minimum thickness of .019 inches for the first 3 feet (1 meter). Ductwork must be firmly attached, secured and sealed to prevent air leakage. Do not use duct liner on inside of supply duct within 4 feet (122cm) of the unit.

Galvanized metal duct extensions should be used to simplify connections to duct work and grilles. Use fabric boots to prevent the transmission of vibration through the duct system. The fabric must be U.L. rated to a minimum of 197°F (92°C).

Minimum Airflow Requirements

The duct system must be engineered to assure sufficient air flow through the unit even under adverse conditions such as dirty filters, etc. Use **Table 6** below and **Table 1, CFM at External Static Pressure (Wet Coil)** in section 1.4.

BASIC MODEL	MAXIMUM STATIC
AVPA/AVHA12	.25
AVPA24/AVHA20/24	.30
AVPA/AVHA30/36	.40
AVPA42/48/60/72 & AVHA42/48/60	.50
HVEA24	.50
HVEA30/36/42 and HVESA36/42	.50
HVEA49/60 & HVESA49/60	.50
AVHSA72	.50

**Table 6. Maximum Static Pressure
(For units with 2” Pleated Filters)**

2.5 Fresh Air Hood (non-economizer air conditioners only)

The fresh air hood is located on the inside, behind the slots on the bottom front panel. To access the hood, remove the screws that hold the front panel. The air flow can be adjusted from no (0%) fresh air to approximately 15% of rated air flow of fresh air, in 5% increments. The hood is shipped from the factory in the closed position (no fresh air). To provide fresh air, remove the two screws on either side of the hood and reposition as desired.

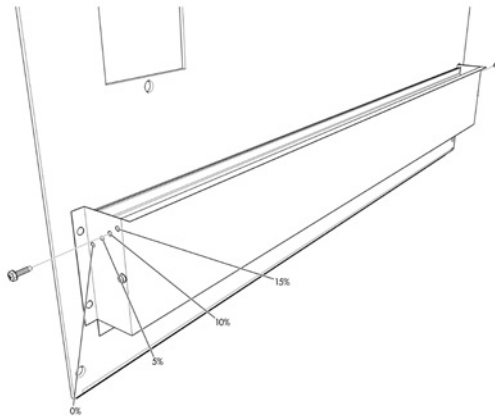

Figure 7a. Fresh Air Hood Damper, Models 24-72

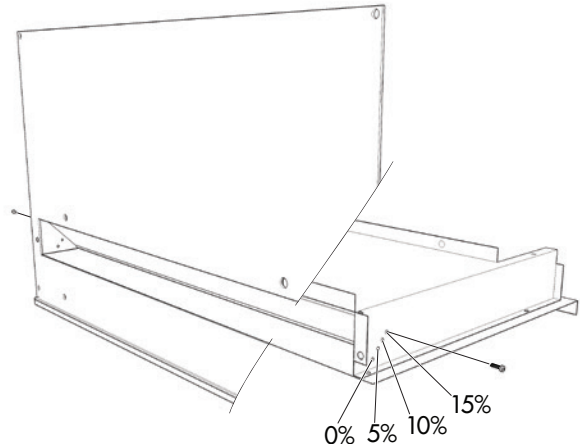

Figure 7b. Fresh Air Hood Damper for AVPA/AVHA12

2.6 Bracket Installation

1. All models have built-in mounting flanges.
2. Apply a bead of silicone sealer on the wall side of the bottom support brackets on the unit. Circle the mounting holes with the silicone bead.
3. Refer to Figure 4. Attach the bottom support bracket to the wall using appropriate 3/8" diameter hardware. **Note: the AVPA12 air conditioners do not require a bottom support bracket.**

For example, on wooden structures, use 3/8" x 2-1/2" all-thread lag screws. The screws must penetrate the center of the wall stud. Drill a pilot hole in the stud to prevent it from splitting.

2.7 Mounting The Unit

1. For wiring into the back of unit, locate the lower of the two knockouts on the wall side of the unit. Drill a one inch hole in the shelter wall to match this opening. Allow sufficient clearance to run 3/4" conduit through the hole and to the unit.
2. Using an appropriate and safe lifting device, set the unit on the bottom support bracket mounted on the wall. You must stabilize the unit on the bracket with the lifting device or by some other means - the bracket alone is not sufficient.
3. Make sure that the duct flanges are properly aligned with the wall opening. Adjust as necessary.
4. Note the holes in each side flange. Using the holes for guides, drill holes through the wall with a 3/8" drill bit. Insert the 3/8" x 5" bolts through the flanges. Install nuts and washers on the inside of the shelter. Tighten the bolts to secure the unit.
5. Apply a bead of silicone where the mounting flange contacts the unit and the shelter wall.
6. On the inside of the shelter, install the wall sleeves in the supply and return air openings. The sleeves may be trimmed to fit flush with the inside wall.
7. Check the fit of each sleeve to its mating flange for possible air leaks. Apply silicone sealer to close any gaps. Install the air return and supply grilles.

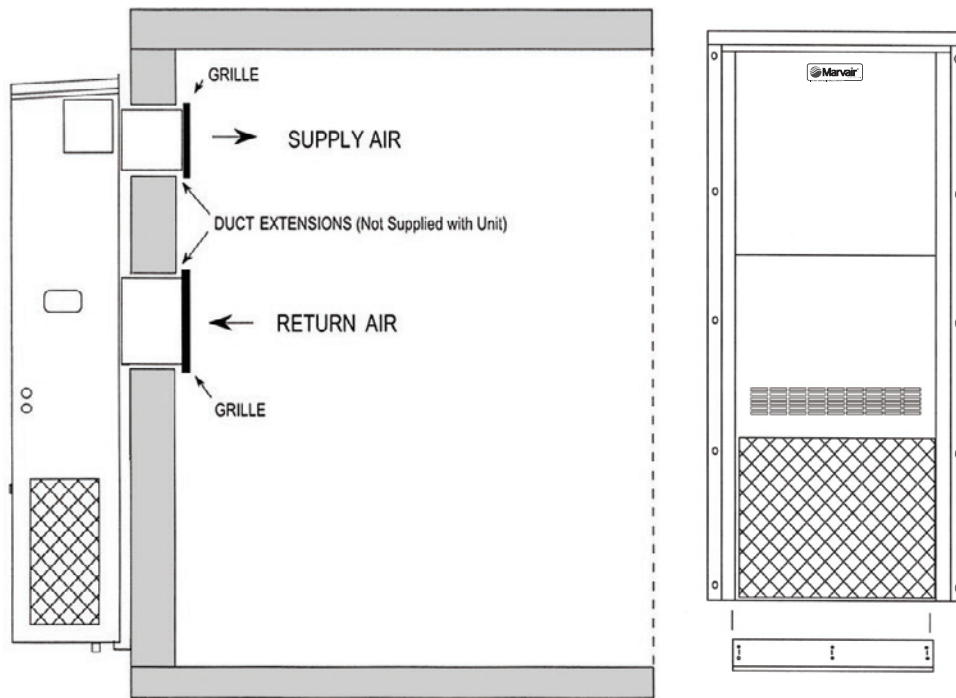

For units with electric heat, a one inch clearance is required around the duct extensions. The duct extensions must be constructed of galvanized steel with a minimum thickness of .019" as per the NFPA standards 90A & 90B.

Figure 8a. ComPac® A/C+ Wall Mount Detail

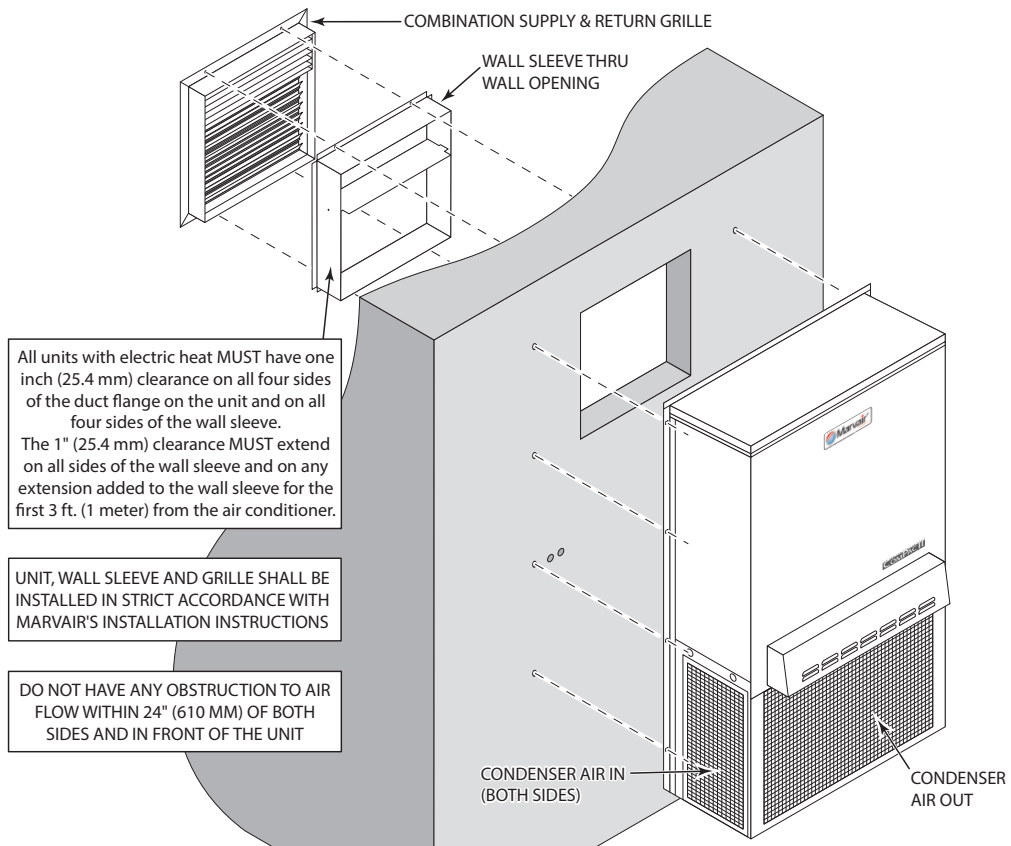
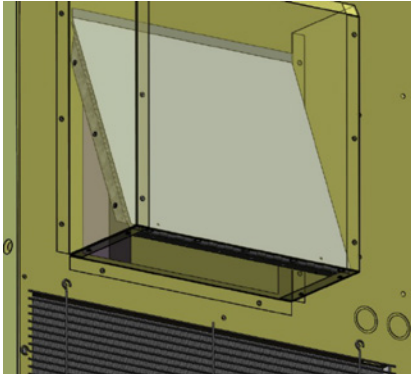

Figure 8b. AVPA/AVHA12 ComPac Wall Mount Detail

2.8 Vertical Economizer and Gravity Dampers (HVESA36/60 & AVHSA72 Models Only)



Gravity Dampers: There is a gravity-operated economizer exhaust outlet damper located on each side of the HVESA unit. The dampers are covered by a hood to exhaust the air in upward direction, away from the economizer inlet. The hood also prevents rain, debris and pests from entering the unit.

The gravity damper is limited to 85 degrees of travel and doesn't pass the 90 degree position so the weight of the damper always makes it rotate at the hinge point and close the room exhaust air outlet.

Note: The gravity dampers ship uninstalled with all units and are field installed.

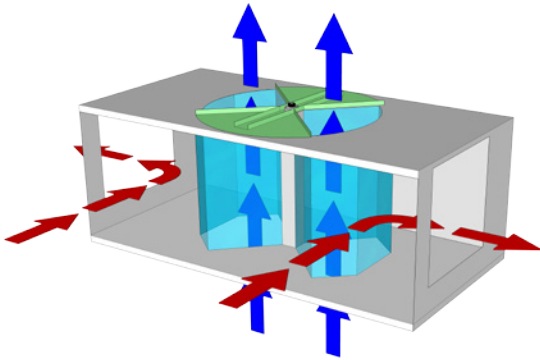

Economizer Open: During economizer operation, the sectors at 12 O' clock and 6 O' clock position are closed by the bow tie damper. This allows fresh air to be brought into the unit through the condenser section of the unit and enter the 3 O' clock and 9 O' clock sectors on the bottom plate and the top plate into the blowers and pushed inside the room through supply grille. Once the shelter is pressurized, the gravity dampers on the sides of the unit open to allow the warm room exhaust to exit the shelter. No re-ingestion of the air is allowed because the cold air is drawn in through the bottom of the unit and warm air exhausted above it in the middle part of the unit.

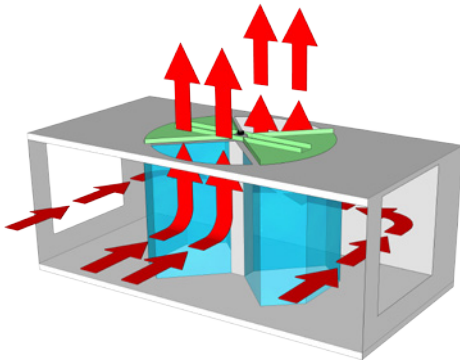

Economizer Closed: The sectors at 3 O' clock and 9 O' clock position are closed during mechanical cooling (non-economizer operations) as shown. No fresh air is being drawn into the unit and room air is recirculated by passing through 12 O' clock and 6 O' clock sectors and into the evaporator, cooled and is then returned to the room. The gravity damper is closed during this operation since the room is not pressurized.

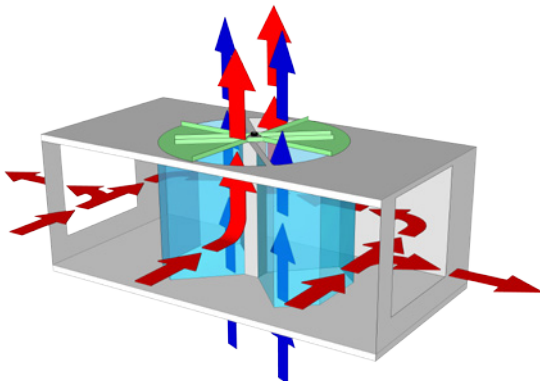

Economizer Modulating: During operation when the outside air is cold enough to satisfy the heat load in the room and there is a need to modulate to maintain a set mixed air temperature, the bow tie damper rotates and partially closes the sectors as shown to provide a proper mix of outside air and room air to maintain the mixed air temperature without dropping below a set point. The gravity damper partially opens and closes as needed to maintain the airflow balance.

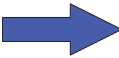
Cool Outside Air

Warm Return Air from Shelter Interior

2.9 Electrical Connections



WARNING

ELECTRICAL SHOCK HAZARD

Failure to follow safety warnings exactly could result in serious injury, death, and/or property damage.

Turn off electrical power at fuse box or service panel BEFORE making any electrical connections and ensure a proper ground connection is made before connecting line voltage.

Important

All electrical work must meet the requirements of local codes and ordinances. Work should be done **only** by qualified persons.

ComPac® units may incorporate an internal crankcase heater for compressor protection. **The crankcase heater must be energized for at least 24 hours prior to starting the compressor.**

Scroll compressors, like several other types of compressors, will only compress in one rotational direction. The direction of rotation is not an issue with single-phase compressors since they will always start and run in the proper direction. However, three phase compressors will rotate in either direction depending upon phasing of power. Since there is a 50-50 chance of connecting power in such a way as to cause rotation in the reverse direction, it is imperative to confirm that the compressor is rotating in the proper direction at the initial field start-up of the system. Verification of proper rotation is made by observing that the suction pressure drops and the discharge pressure rises when the compressor is energized. An alternate method of verification for self contained system with small critical refrigerant charges, where the installation of gauges may be objectionable, can be made by monitoring the temperature of the refrigerant lines at the compressor. The temperature should rise on the discharge line while the suction line temperature decreases. Reverse rotation also results in a substantially reduced current draw when compared to tabulated values.

There is no negative impact on durability caused by operating three phase compressors in the reversed direction for a short duration of time, usually defined as less than one hour. However, after several minutes of operation the compressor's internal protector will trip. The compressor will then cycle on the protector until the phasing is corrected. Reverse operation for longer than one hour may have a negative impact on the bearings.

To change the rotation, turn off power to the unit and reverse L1 & L2 at the disconnect in the air conditioner.

High Voltage Wiring - (Single Units)

The power supply should have the proper voltage, phase, and ampacity for the selected model.

1. Refer to the electrical data on the data sticker on the unit for field wiring requirements of the unit. Size the incoming power supply lines and the fuse(s) or HACR breaker(s) according to requirements described in the National Electric Code. Run the power conductors through the knockouts on the side or back of the unit. Use appropriate conduit and strain reliefs.



CAUTION

Note: Power supply service must be within allowable range (+10% - 5%) of rated voltage stamped on the unit rating plate. To operate nominal 230/208V unit at 208V, change the transformer line tap from 240V to 208V following the instruction on wiring label in unit.

2. Connect the wires to the input side of the internal breaker or terminal block (L1 & L2 for single-phase units; L1, L2, & L3 for three-phase models).
3. Install the ground wire on the ground lug.
4. For units designed for operation on 208/230V, 60Hz power supply, the transformer is factory wired for a 230V power supply. For a 208V power supply, remove the orange lead from the transformer and connect the red lead. Insulate the orange lead.
5. 460V units have a step down transformer for 230V motors.

⚠ CAUTION

The external breaker(s) that provide power to the air conditioner must be sized per the maximum Fuse Size (MFS) shown on the Unit's data label.

Dual Unit Phasing

For applications where one controller operates two units, e.g., the CommStat 4 or CommStat Touch HVAC controller.

Newer HVAC controllers such as the CommStat do not require unit phasing. However, if other devices are connected to the control system, phasing of the air conditioner is required. Earlier models; i.e., LL357, LL357A, LL357D2 require the unit to be properly phased.

1. Wire each unit as described in steps 1 through 4 above.
2. Test for proper phasing as follows:
 - A. Power up the units.
 - B. Using an AC volt meter set to the 300 volt scale, measure voltage between terminal L1 on the compressor contactor of unit #1 and terminal L1 on the compressor contactor of unit #2. If voltage is present, units are wired out of phase and must be rewired.
 - C. If units are not in phase, turn off power and reverse the field power leads connected to the internal circuit breaker on one of the units only.
 - D. Restore power and retest the phase (step B). When the voltage reads "0", the units are in phase.
 - E. Turn off power and proceed.

Low Voltage Wiring

IMPORTANT. The following instructions are generic wiring instructions and may not be applicable for air conditioners with various options. Always refer to the wiring diagram in the air conditioner for the proper method to wire your unit.

1. On single units, pull the low voltage wiring (e.g., 18 gauge 4-conductor Class 2 thermostat wire) from the ComPac unit into the thermostat / subbase assembly. See Figure 9b for connections to various thermostats.
2. Mount the thermostat on the wall of the shelter. The thermostat should be located so that the supply air from the unit does NOT blow directly on to the thermostat. Connect the thermostat to the terminal block in the air conditioner as shown in Figures 9a and 9b.
3. On dual units, refer to the *CommStat Touch, CommStat 4 or CommStat 3 HVAC Controller Specification sheet*. Level and install the controller subbase. Wire the two A/C units to the Lead/Lag Controller, according to the wiring diagram on the specification sheet and as shown in Figure 9c or 9d (note: the diagram also appears on the back cover of the controller).

Remote Signalling: Terminals 5 & 7(N.O.) and 6 & 7 (N.C.) on the terminal board are dry contacts which can be used for remote signalling in the event of a/c cutoff on low or high pressure limit.

Continuous fan operation: For continuous indoor fan operation on single units, install a jumper between terminals 8 and 3. For continuous indoor fan operation on dual units using the older LL357D4, install jumper between 8 and 3 and remove jumper between 1 and 3.

CommStat Touch Lead /Lag Controller (See Figure 9c)

Please refer to the Product Data sheet for the Commstat Touch controller for complete instructions on installing and programming this controller.

CommStat 4 Lead /Lag Controller

Please refer to the Product Data sheet for the Commstat 4 controller for complete instructions on installing and programming this controller.

CommStat 3 Controller (See Figure 9d)

The CommStat 3 Controller is a solid state control package designed to operate a fully or partially redundant air conditioning system for a telecommunication cabinet or shelter. The CommStat 3 Controller is factory programmed with standard industry set points to facilitate installation. If desired, each of the set points can be quickly and easily changed in the field by the installer. It can be used with the ComPac's unique vertical packaged wall mount air conditioners or other environmental control units. See CommStat 3 Product Data Sheet for installation and programming instructions.

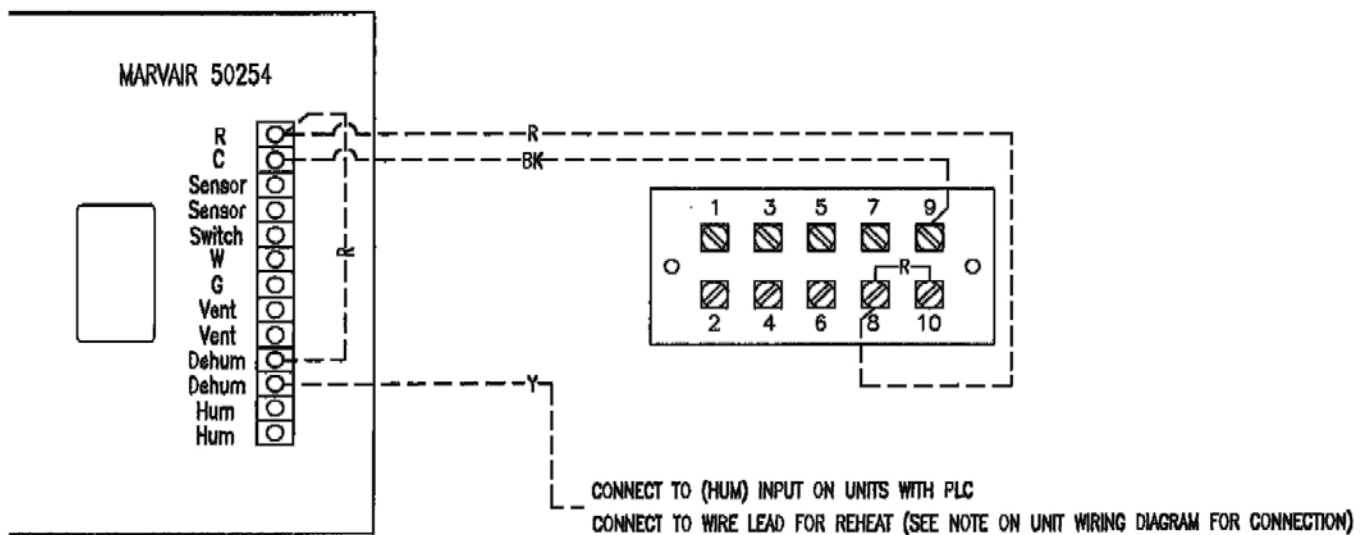

Figure 9a. Humidistat (P/N 50254) Wiring to a ComPac® Air Conditioner with Reheat.

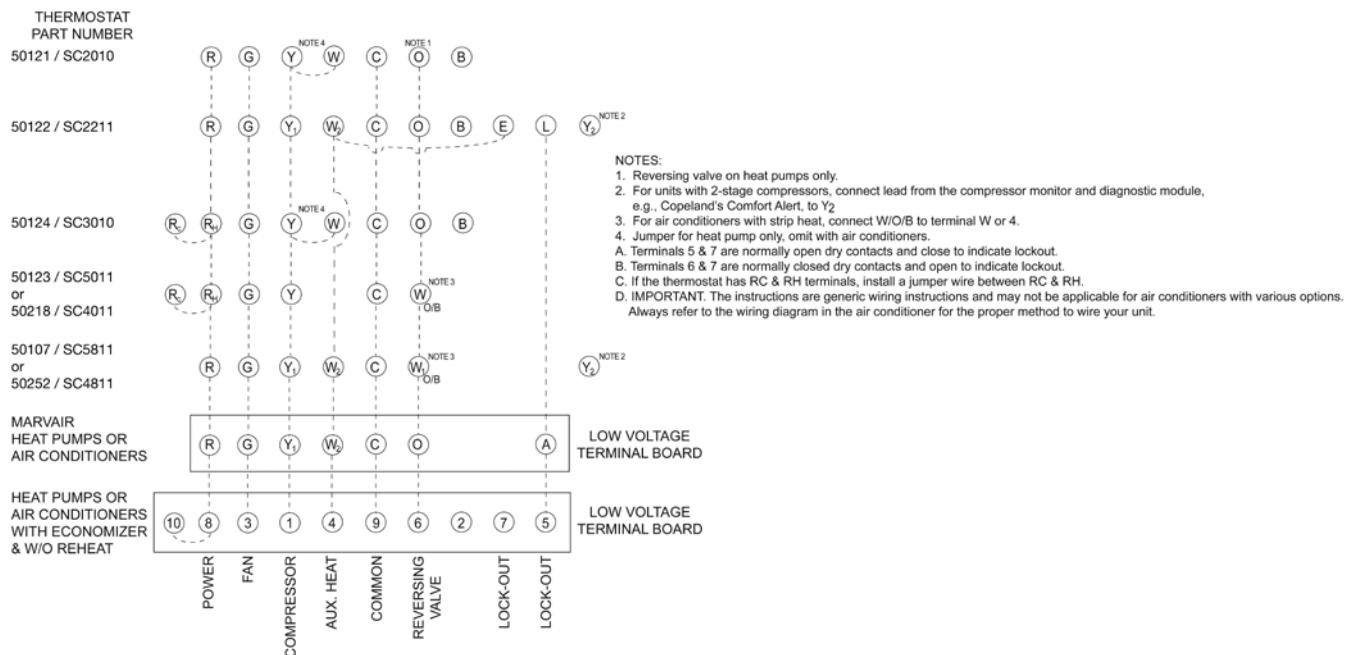

Figure 9b. Thermostat Connection Diagram

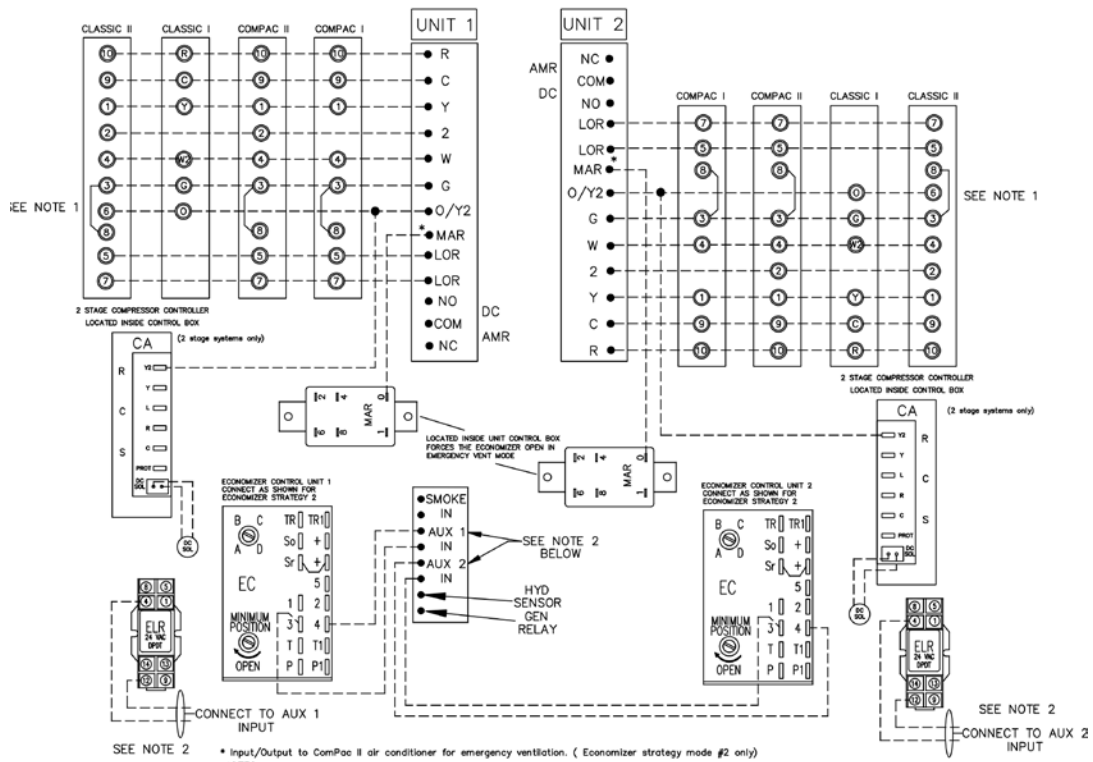

Figure 9c. CommStat Touch Wiring Diagram

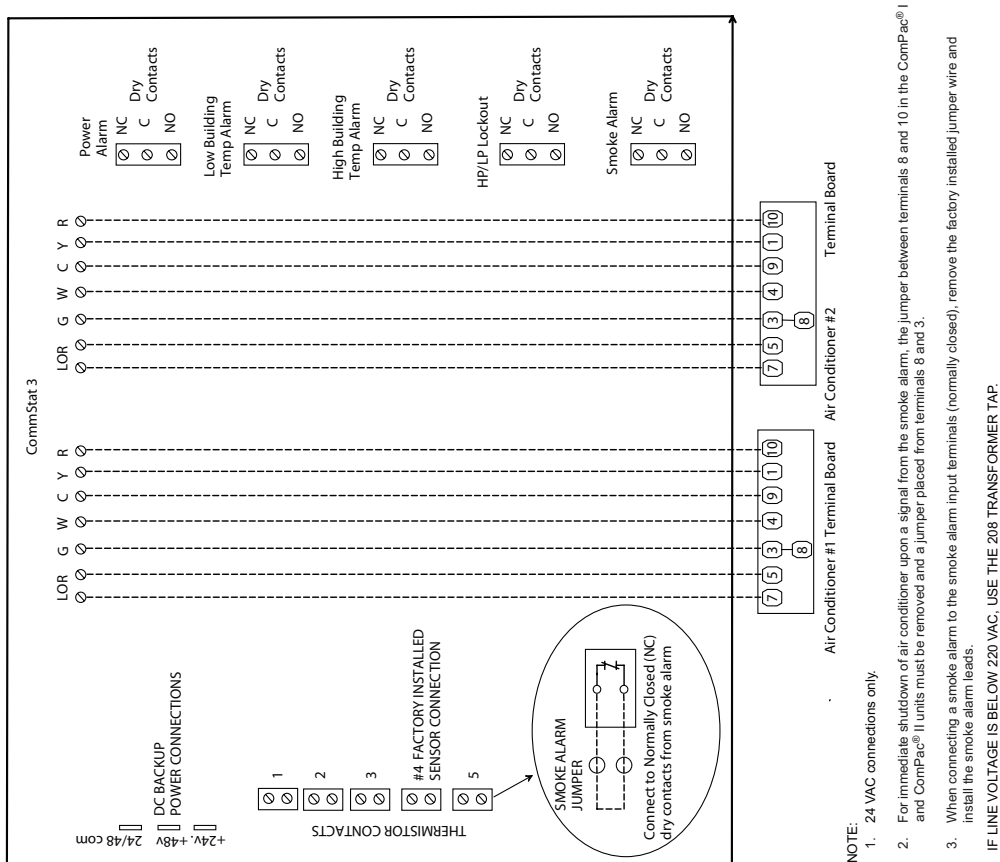

Figure 9d. CommStat 3 Wiring Diagram

Chapter 3 Start-Up

3.1 Check-Out of Cooling Cycle

Important: Be sure that the crankcase heater (if used) has been energized for at least 24 hours before starting the unit(s). Double-check all electrical connections before applying power. ComPac® air conditioners with scroll compressors running on 3Ø power must be checked for proper rotation during the initial start-up. Please refer to Section 2.8 for determining if the 3Ø compressors are rotating correctly. Incorrect rotation can damage the compressor and is not covered by the warranty

Procedure:

1. Set the cooling set point temperature on the wall thermostat to a point *higher* than the ambient temperature. Set the heating set point temperature to a temperature that is *lower* than the ambient.
2. Set the thermostat system switch in the AUTO position. Nothing should operate at this time.
3. Set the time delay in the electrical control box to three minutes. Check the changeover setting of the enthalpy or dry bulb sensor and reset it if needed (economizer-equipped models only). See Section 1.6.
4. Slowly lower the thermostat's cooling set point temperature until the switch closes. The indoor fan should operate.

Once the indoor fan turns on, allow approximately three minutes for the compressor to start. Note that the outdoor fan may not come on immediately, because it is cycled by refrigerant pressures.

NOTE: (Economizer-Equipped models only) To check the system operation under different ambient conditions, the air temperature and enthalpy sensors must be "tricked". When outdoor ambient conditions are higher than the control setting, a component cooler aerosol may be sprayed directly into the enthalpy sensor to simulate low enthalpy conditions, causing the economizer damper to open.

Alternately, when outdoor conditions are lower than the set point, a source of heat such as a hair dryer can be directed on the air temperature sensor to simulate warmer conditions, which will bring on mechanical cooling and start the compressor.

5. To stop cooling, slowly raise the thermostat cooling set point to a temperature higher than the ambient.

If the unit fails to operate, refer to the troubleshooting information in Chapter 4.

Follow the same procedure for additional units.

NOTE: The fan purge allows the indoor fan to run for approximately 90 seconds after the compressor is off. This operation provides a small improvement in system rated efficiency.

3.2 Check-Out of Heating Cycle

Procedure: (Applies only to units with resistance elements)

1. Raise the heating set point temperature to a setting which is higher than the ambient temperature. The fan and electric heat should immediately cycle on.
2. Move the system switch to the "OFF" position. All functions should stop.

NOTE: (Economizer Equipped models only) The damper blade should remain closed during the heating cycle (unless the minimum position potentiometer has been set for constant ventilation) A fully counterclockwise position corresponds to full closure of the damper.

Chapter 4 Troubleshooting

4.1 Overview

A comprehensive understanding of the operation of the ComPac® is a prerequisite to troubleshooting. Please read the Chapter 1 for basic information about the unit.

ComPac air conditioners are thoroughly tested before they are shipped from the factory. Although unlikely, it is possible that a defect may escape undetected, or damage may have occurred during transportation. However, the great majority of problems result from installation errors.

If you experience difficulties with your ComPac unit, please review the installation steps in Chapter 2.

Much time can be saved by taking a thoughtful and orderly approach to troubleshooting. Start with a visual check - are there loose wires, crimped tubing, missing parts, etc? Begin deeper analysis only after making this initial inspection.

The troubleshooting information in this manual is basic. The troubleshooting section contains problem/solution charts for general problems, followed by a compressor section.

Not every problem can be anticipated. If you discover a problem that is not covered in this manual, we would be very grateful if you would bring it to the attention of our service department for incorporation in future revisions.

As always, please exercise caution and good judgement when servicing the unit. Use only safe and proven service techniques. Use refrigeration goggles when servicing the refrigeration circuit.

WARNING

The refrigerant circuit has hot surfaces, and the electrical voltages inside of the unit may be hazardous or lethal. SERVICE MAY BE PERFORMED ONLY BY QUALIFIED AND EXPERIENCED PERSONS.

4.2 Failure Symptoms Guide

PROBLEM/SYMP TOM	LIKELY CAUSE(S)	CORRECTION
<p>A. Unit does not run.</p> <p>NOTE: An internal anti-short-cycle timer will prevent the unit from starting for .2 to 8 minutes following start-up.</p>	<ol style="list-style-type: none"> 1. Power supply problem. 2. Tripped internal disconnect. 3. Shut off by external thermostat or thermostat is defective. 4. Unit off on high or low pressure limit. 5. Internal component or connection failure. 	<ol style="list-style-type: none"> 1. Check power supply for adequate phase and voltage. Check wiring to unit and external breakers or fuses. 2. Check internal circuit protection devices for continuity. 3. Check operation of wall-mounted thermostat. 4. Reset pressure switch. 5. Check for loose wiring. Check components for failure.
<p>B. Unit runs for long periods or continuously; cooling is insufficient.</p>	<ol style="list-style-type: none"> 1. Dirty filter or reduced airflow 2. Low refrigerant. 3. Component failure. 4. Unit undersized for job. 	<ol style="list-style-type: none"> 1. Check air filter(s). Check blower operation. Remove airflow restriction. 2. Check for proper charge and possible refrigerant leak. 3. Check internal components, especially compressor for proper operation. 4. Add additional units for greater capacity.

PROBLEM/SYMPTOM	LIKELY CAUSE(S)	CORRECTION
C. Unit cycles on high/low pressure limit.	<ol style="list-style-type: none"> 1. Loss or restriction of airflow. 2. Restriction in refrigerant circuit. 3. Refrigerant overcharge (following field service) 4. Defective pressure control. 	<ol style="list-style-type: none"> 1. Check blower assembly for proper operation. Look for airflow restrictions, e.g., the air filter. Check blower motor and condenser fan. 2. Check for blockage or restriction, especially filter drier and capillary tube assembly. 3. Evacuate and recharge to factory specifications. 4. Check limit cutout pressures. Control is set to actuate at approximately 35 PSIG (low pressure) and 400 PSIG (high pressure).
D. Unit blows fuses or trips circuit breaker.	<ol style="list-style-type: none"> 1. Inadequate circuit ampacity. 2. Short, loose, or improper connection in field wiring. 3. Internal short circuit. Loose or improper connection(s) in unit. 4. Excessively high or low supply voltage or phase loss (3Ø only). 	<ol style="list-style-type: none"> 1. Note electrical requirements in Chapter 2 and correct as necessary. 2. Check field wiring for errors. 3. Check wiring in unit. See wiring and schematic diagrams. Test components (especially the compressor) for shorts. 4. Note voltage range limitations specific to the compressor troubleshooting section.
E. Water on floor near unit.	<ol style="list-style-type: none"> 1. Obstruction in condensate line. 2. Obstruction or leak in condensate pan. 3. Unit is not level. 	<ol style="list-style-type: none"> 1. Check for clog or restriction. 2. Check pan for leak or blockage. 3. Level unit.
F. No space heating or reduced heating (units equipped with resistance elements)	<ol style="list-style-type: none"> 1. Defective heating element(s). 2. Thermal limit open. 3. Defective heater contactor. 	<ol style="list-style-type: none"> 1. Check resistance element(s) for continuity. 2. Check continuity across thermal limit switch. 3. Check relay for proper operation. Replace if defective.

4.3 Compressor Troubleshooting

NOTE: It is important to rule out other component failures before condemning the compressor.

The following electrical tests will aid diagnosis:

1. **Start-Up Voltage:** Measure the voltage at the compressor contactor during start-up. The voltage must exceed the minimum shown in Table 5, section 2.2, or compressor failure is likely. A low voltage condition must be corrected.
2. **Running Amperage:** Connect a clip-on type ammeter to the (common) lead to the compressor. Turn on the supply voltage and energize the unit. The compressor will initially draw high amperage; it should soon drop to the RLA value or less. If the amperage stays high, check the motor winding resistances.

NOTE: Feel the top of the compressor to see if it has overheated. If it is hot, the internal overload may be open. You may have to wait several hours for it to reset.

3. **Motor Winding Resistances:** Using a digital volt-ohm meter (VOM), measure the resistance across the compressor windings as shown below.

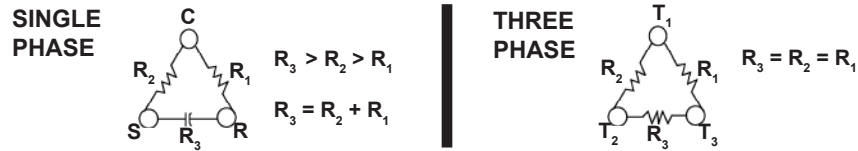

Resistance can be measured as shown above. Any deviation from above values could indicate a defective compressor.

4. **High Voltage/Insulation Test:** Test internal leakage with a megohmmeter. Attach one lead to the compressor case on a bare metal tube and to each compressor terminal to test the motor windings. A short circuit at high voltages indicates a motor defect. Do not do this test under vacuum.
5. On single phase models, check the capacitor by substitution.

4.4 Control Board Diagnosis

The control board (see section 1.6a for a complete description of the control board) has a red diagnostic LED which indicates the lockout fault. The control board will enter into and indicate lockout if either of the fault conditions (LPS or HPS) occur twice.

The contactor must be closed before the first fault condition can be recognized by the control board. The contactor will be closed 3 minutes after the unit is energized and only if cooling is required. The first fault condition will open the contactor and shutdown the unit. The contactor on the unit that has the fault condition must be closed before the second fault condition can be recognized by the control board. The contactor on the unit with the fault condition will close after 3 minutes if the unit is still calling for cooling and if the fault condition no longer exists. If you get a second fault condition, the contactor will open and shutdown the unit. The “red” led will have one blink if the high pressure switch has opened twice and will have two blinks if the low pressure switch has opened twice. The unit must be in the cooling mode (compressor contactor Closed) before a fault condition can occur.

Chapter 5 Maintenance

5.1 Scheduled Maintenance

Airxcel Commercial Group strongly recommends that the air conditioner be serviced a minimum of twice a year – once prior to the heating season and once prior to the cooling season. At this time the filters, evaporator coil, condenser coil, the cabinet, and condensate drains should be serviced as described below. Also at this time, the air conditioner should be operated in the cooling and heating cycles as described in Chapter 3, Start-Up. In addition to this seasonal check-out, the ComPac® should be maintained as follows:

Air Filter

Replace the air filter whenever it is visibly dirty. Never operate the unit without the filter in place.

Evaporator

If the evaporator becomes clogged or dirty, it may be cleaned by careful vacuuming or with a commercial evaporator cleaning spray. DO NOT use a solvent containing bleach, acetone, or flammable substances. Turn off power before cleaning. Be careful not to wet any of the electrical components. Be sure the unit has dried before restarting.

Condenser

Periodically inspect the outdoor condenser coil and the cabinet air reliefs for dirt or obstructions. Remove foreign objects such as leaves, paper, etc.

If the condenser coil is dirty, it may be washed off with a commercial solvent intended for this purpose. **TURN OFF POWER BEFORE CLEANING!** Be sure that all electrical components are thoroughly dry before restoring power. Use a fin comb of the correct spacing to straighten mashed or bent fins.

Cabinet

The cabinet may be cleaned with a sponge and warm, soapy water or a mild detergent. Do not use bleach, abrasive chemicals or harmful solvents.

Drains

Regularly check the primary and secondary condensate drains. The secondary drain has a stand pipe. An obstruction will force water to dump into the middle of the unit and drain out the sides of the ComPac, causing discoloration of the side panels. If discoloration is noted, service the drains.

If a commercial drain solvent is used, flush out the drain pan and system with plenty of fresh water to prevent corrosion.

Lubrication

Oiling of the condenser fan motor or the evaporator blower motor is not recommended.



Sever hazard. The economizer contains moving parts capable of causing serious injury or death. Disconnect power before removing the covering panel.

Chapter 6 Warranty

6.1 Airxcel Commercial Group Limited Product Warranty

Airxcel Commercial Group (ACG) warrants its products to be free from defects in materials and workmanship under normal use to the original purchaser when installed within the contiguous United States, the District of Columbia, and Canada for the period of time in the table below. For units installed in Alaska and Hawaii, flat labor rates apply. If any part of your ACG product fails within 15 months from the date of the original shipment, or within twelve months from the date of original start-up, whichever comes first, ACG will furnish without charge, EXW Cordele, Georgia, the required replacement part. The owner must provide proof of the date of the original start-up. The contractor's invoice, the certificate of occupancy, or similar documents are examples of acceptable proof of the date of the original start-up.

Marvair, ICE, Eubank	Suburban Applied Products
90 Days DOA* w/Flat Rate Labor	1 Year Parts/Labor – Flat Rate
1 Year Parts	5 Years Heat Exchanger
5 Years Compressor	5 Years Compressor

*If any part of your ACG unit fails within 90 days of the commencement of the warranty, ACG will furnish without charge, EX Works, Cordele, Georgia, the required replacement part and pay for the labor to replace the part in accordance with the ACG Flat Rate Labor Guidelines.

The following extra cost warranties are available from Airxcel Commercial Group:

Bronze	Silver	Gold	Diamond
Any Special Warranty Written for a Job	1 Year Parts/Labor	2 Years Parts/Labor	5 Years Parts/Labor

The responsibility of the equipment owner includes:

4. To operate the equipment in accordance with the manufacturer's instructions.
5. To provide easy accessibility for servicing.
6. To check and reset any circuit breaker(s) and/or disconnect(s) prior to calling for service.
7. To keep the unit clean and free of dirt and containment and replace filters as required.
8. To keep the outdoor coil clean and free of leaves, paper, or other debris.
9. To pay the charges incurred when any of the above have not been done.
10. To pay for repair or replacement of any material or part other than those within the ACG unit or controller.

ACG will not be responsible for labor, transportation costs, delays or failures to complete repairs caused by events beyond our control. This warranty does not cover:

1. Any transportation, related service labor, diagnosis calls, filter, driers, refrigerant, or any other material charges.
2. Damages caused by shipping, accident, abuse, negligence, misuse, fire, flood, or Acts of God.
3. Damages caused by operating or staging the unit in a corrosive environment
4. Damages caused by improper application of the product.
5. Damages caused by failing to perform proper routine maintenance.
6. Expenses incurred for erecting, disconnecting or dismantling the product or installing the replacement part(s).
7. Products not installed or operated according to the included instructions, local codes, and good trade practices.
8. Products moved from the original installation site.
9. Products lost or stolen
10. Consequential damages or incidental expenses including losses to persons, property or business.
11. Modifications to original unit after it leaves the factory, such as breaking the any part of the sealed systems.

When service is required, it must be performed during normal working hours (8:00 AM - 5:00 PM) Monday - Friday and must be performed by ACG personnel or a designated Service Representative. ACG will pay for non-priority shipping costs of the compressor during the first twelve months of the warranty period. After the first twelve months of the warranty period, all costs of shipment and risk of loss during the shipment of the compressor shall be the responsibility of the owner.

The owner of the product may ship the allegedly defective or malfunctioning product or part to ACG, at such owner's expense, and ACG will diagnose the defect and, if the defect is covered under this warranty, ACG will honor its warranty and furnish the required replacement part. All costs for shipment and risk of loss during shipment of the product to ACG and back to the owner shall be the responsibility and liability of the owner. Upon written request by an owner, ACG may arrange for remote diagnosis of the allegedly defective or malfunctioning product or part but all costs for transportation, lodging and related expenses with regard to such diagnostic services shall be the responsibility and liability of the owner.

An owner requesting performance under this Warranty shall provide reasonable access to the allegedly defective or malfunctioning product or part to ACG and its authorized agents and employees.

THIS WARRANTY CONSTITUTES THE EXCLUSIVE REMEDY OF ANY PURCHASER OF AN AIRXCEL COMMERCIAL GROUP HEAT PUMP OR AIR CONDITIONER AND IS IN LIEU OF ALL OTHER WARRANTIES, EXPRESSED OR IMPLIED, INCLUDING, WITHOUT LIMITATION, ANY IMPLIED WARRANTY OF MERCHANTABILITY OR FITNESS FOR USE, TO THE FULLEST EXTENT PERMITTED BY LAW. IN NO EVENT SHALL ANY IMPLIED WARRANTY OF MERCHANTABILITY OR FITNESS FOR USE EXCEED THE TERMS OF THE APPLICABLE WARRANTY STATED ABOVE AND AIRXCEL COMMERCIAL GROUP SHALL HAVE NO OTHER OBLIGATION OR LIABILITY. IN NO EVENT SHALL MARVAIR BE LIABLE FOR INCIDENTAL OR CONSEQUENTIAL DAMAGES OR MONETARY DAMAGES.

THIS WARRANTY GIVES YOU SPECIFIC LEGAL RIGHTS, AND YOU MAY ALSO HAVE OTHER RIGHTS WHICH VARY FROM STATE-TO-STATE. Some states do not allow limitations or exclusions, so the above limitations and exclusions may not apply to you.

EXPLODED VIEWS AND PARTS LISTS

Current parts lists and exploded views of the unit can be found on our web site at www.Marvair.com. Click on the Service and Parts in the menu on the left hand side of the Home page. From the drop down menu, select Exploded Views. Once here, you can select your air conditioner or heat pump. The units are grouped by model and by the refrigerant – R-22 or R-410A.

APPENDIX A: Installation Instructions for Field Installed Electric Heat, Models 20-72

WARNING FIRE HAZARD

Improper adjustment, alteration, service, maintenance or installation could cause serious injury, death and/or property damage.

Installation or repairs made by unqualified persons could result in hazards to you and others. Installation **MUST** conform with local codes or, in the absence of local codes, with codes of all governmental authorities have jurisdiction.

The information contained in this manual is intended for use by a qualified service agency that is experienced in such work, is familiar with all precautions and safety procedures required in such work, and is equipped with the proper tools and test instruments.

Duct Work

General Information

Note: The following instructions are for general guidance only. Due to the wide variety of installation possibilities, specific instructions will not be given. When in doubt, follow standard and accepted installation practices, or contact Airxcel Commercial Group for additional assistance.

Wall Openings

Measure the dimensions of the supply and return ports on the unit.

Cut the openings in the exterior wall for the supply and return. **IMPORTANT: All units with electric heat must have 1" (25.4 mm) clearance on all four sides of the supply outlet duct flange on the unit. The 1" (25.4 mm) clearance must extend on all sides of the supply duct for the first 3 feet (1 meter) from the unit.**

IMPORTANT: Marvair requires a minimum of 1" (25.4 mm) from the surface of any supply ducts to combustible material for the first 3 feet (1 meter) of the duct.

Ducting

Extensions should be cut flush with the inside wall for applications without duct work.

Applications using duct work should be designed and installed in accordance with all applicable safety codes and standards. Marvair strongly recommends referring to the current edition of the National Fire Protection Association Standards 90A and 90B before designing and installing duct work. The duct system must be engineered to insure sufficient air flow through the unit to prevent over-heating of the heater element. This includes proper supply duct sizing, sufficient quantity of supply registers, adequate return and filter area. Ductwork must be of correct material and must be properly insulated. Duct work must be constructed of galvanized steel with a minimum thickness of .019 inches for the first 3 feet (1 meter). Ductwork must be firmly attached, secured and sealed to prevent air leakage. Do not use duct liner on inside of supply duct within 4 feet (122 cm) of the unit. Galvanized metal duct extensions should be used to simplify connections to duct work and grilles. Use fabric boots to prevent the transmission of vibration through the duct system. The fabric must be U.L. rated to a minimum of 197°F (92°C).

 **WARNING**

ELECTRICAL SHOCK HAZARD

Failure to follow safety warnings exactly could result in serious injury, death, and/or property damage.

Turn off electrical power at fuse box or service panel BEFORE making any electrical connections and ensure a proper ground connection is made before connecting line voltage.

Heater installation (see drawings and wiring diagram)

1. Remove top front panel.
2. Remove bottom front panel.
3. Remove the control box cover.
4. Remove the heater access cover plate on the upper right side of the unit by removing the three screws. Cut insulation on two sides and fold down out of way.
5. Slide new heater assembly into place by lining up stem with hole on far end. Make sure stem of new heater assembly is inserted into correct hole. The hole nearest to the indoor coil is for three element heaters and the farthest away from indoor coil is for all other heaters.
6. Install the two No. 10 screws in the heater assembly plate.
7. Install wire harness in hole provided in drain pan and then through filter bracket and then into control box.
8. Wire the heater as shown in the wiring diagram provided with the heater kit (the insulated terminal ends are to be connected at the heater)
9. Install pop tie in appropriate hole in back panel to secure wire.
10. Install closed cell strip around wires where they pass through the drain pan.
11. Reinstall the heater access cover.
12. Mount the heat contactor inside the control box where the mounting holes are provided for the heat contactor.
13. Make the wiring connections inside the control box as shown in the wiring diagram provided with the heater kit. Bundle loose wires with wire ties.
14. With a permanent marker, place an (X) in the space provided next to the heater kit rating of the installed heater on the unit data label.
15. Place the wiring diagram provided with the heater kit inside the zip lock bag which is affixed to the back side of the control box cover.
16. Replace the control box cover, the bottom front cover and the top front panel.

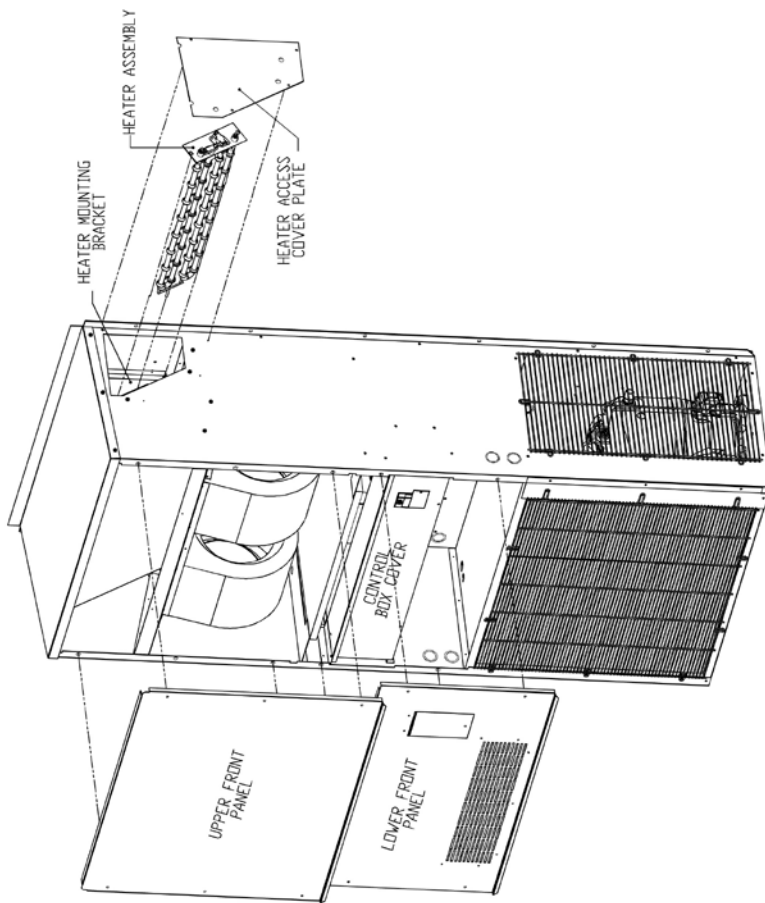

HEATER STEM INSTALLED IN HOLE ON FAR END

HEATER ASSEMBLY INSTALLED WITH TWO #10 SCREWS

